

Features

- Fast switching speed
- High conductance
- Connected in series

HF

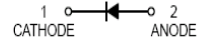

Mechanical Data

- Case: SOD-523
- Molding Compound: UL Flammability Classification Rating 94V-0
- Terminals: Matte tin-plated leads; solderability-per MIL-STD-202, Method 208

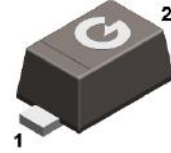

SOD-523

Ordering Information

Part Number	Package	Shipping Quantity	Marking Code
1N4448WT	SOD-523	3000 pcs / Tape & Reel	T5

Maximum Ratings (@ T_A = 25°C unless otherwise specified)

Parameter	Symbol	Value	Unit
Non-Repetitive Peak Reverse Voltage	V _{RM}	100	V
Peak Repetitive Peak Reverse Voltage	V _{RRM}	75	V
Working Peak Reverse Voltage	V _{RWM}	75	V
DC Blocking Voltage	V _R	75	V
RMS Reverse Voltage	V _{R(RMS)}	53	V
Average Rectified Output Current	I _F	250	mA
Non-Repetitive Peak Forward Surge Current, t _p = 1μs	I _{FSM}	4	A
Non-Repetitive Peak Forward Surge Current, t _p = 1s	I _{FSM}	2	A

Thermal Characteristics

Parameter	Symbol	Value	Unit
Power Dissipation	P _D	150	mW
Thermal Resistance Junction-to-Air *1	R _{θJA}	400	°C/W
Thermal Resistance Junction-to-Case *1	R _{θJC}	315	°C/W
Thermal Resistance Junction-to-Lead *1	R _{θJL}	330	°C/W
Operating Junction Temperature Range	T _J	-65 ~ +150	°C
Storage Temperature Range	T _{STG}	-65 ~ +150	°C

Note 1: The data tested by surface mounted on a 1 inch² FR-4 board with 2OZ copper

Electrical Characteristics (@ $T_A = 25^\circ\text{C}$ unless otherwise specified)

Parameter	Symbol	Test Condition	Min.	Typ.	Max.	Unit
Reverse Breakdown Voltage	$V_{(BR)R}$	$I_R = 10\mu\text{A}$	75	-	-	V
Forward Voltage	V_F	$I_F = 5\text{mA}$	-	-	0.720	V
		$I_F = 10\text{mA}$	-	-	0.855	V
		$I_F = 100\text{mA}$	-	-	1.000	V
		$I_F = 150\text{mA}$	-	-	1.250	V
Maximum Peak Reverse Current	I_R	$V_R = 20\text{V}$	-	-	25	nA
		$V_R = 25\text{V}, T_J = 125^\circ\text{C}$	-	-	30	μA
		$V_R = 75\text{V}$	-	-	2.5	μA
		$V_R = 75\text{V}, T_J = 150^\circ\text{C}$	-	-	50	μA
Total Capacitance	C_J	$V_R = 0\text{V}, f = 1.0\text{MHz}$	-	-	4	pF
Reverse Recovery Time	t_{rr}	$I_F = I_R = 10\text{mA}$ $I_{rr} = 0.1 \times I_R, R_L = 100\Omega$	-	-	4	ns

Ratings and Characteristics Curves (@ $T_A = 25^\circ\text{C}$ unless otherwise specified)

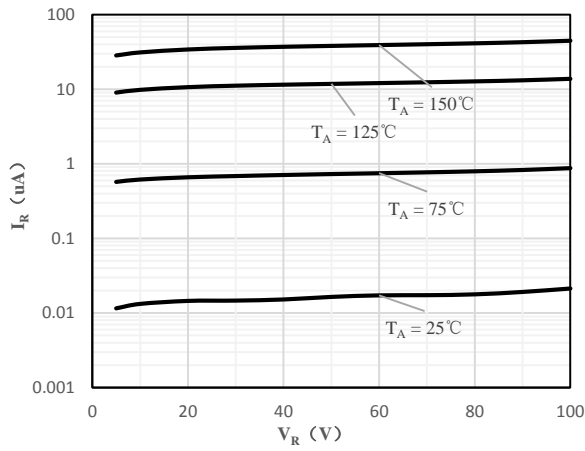

Fig 1 Typical Reverse Characteristic

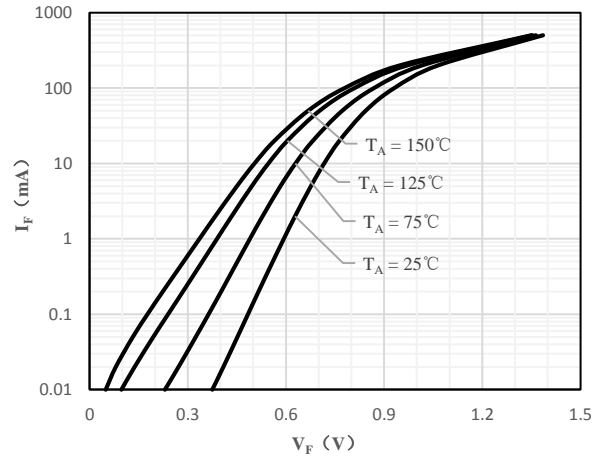

Fig 2 Typical Forward Characteristics

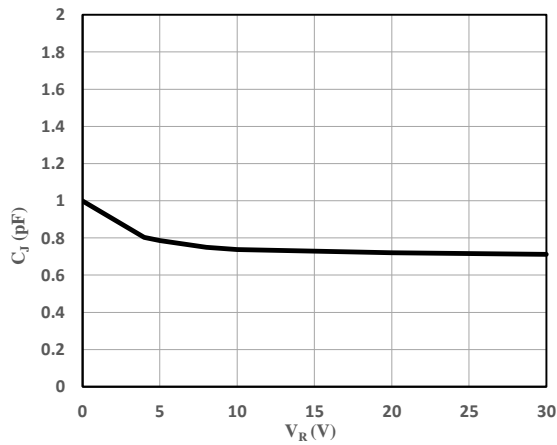

Fig 3 Capacitance vs. Reverse Voltage

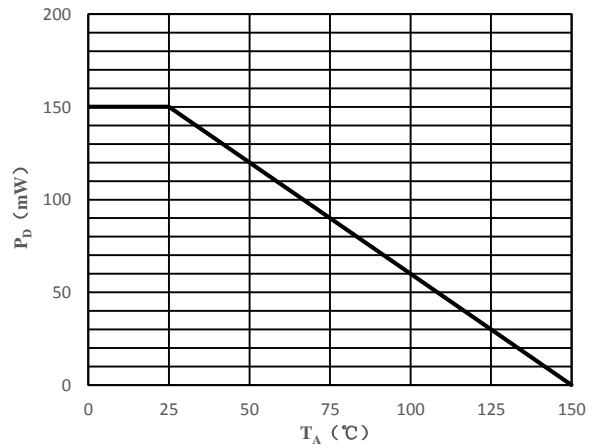
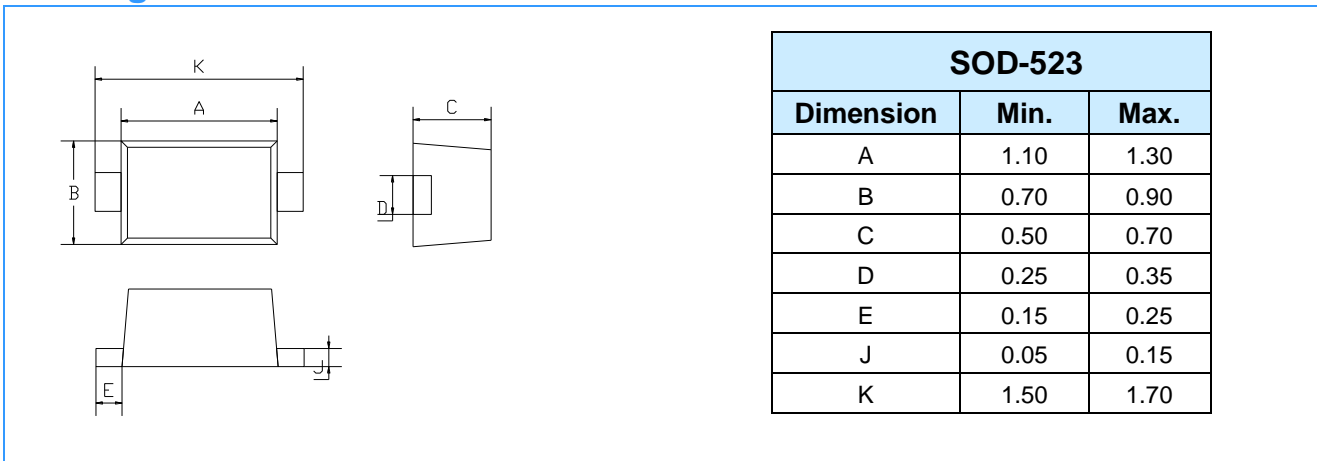
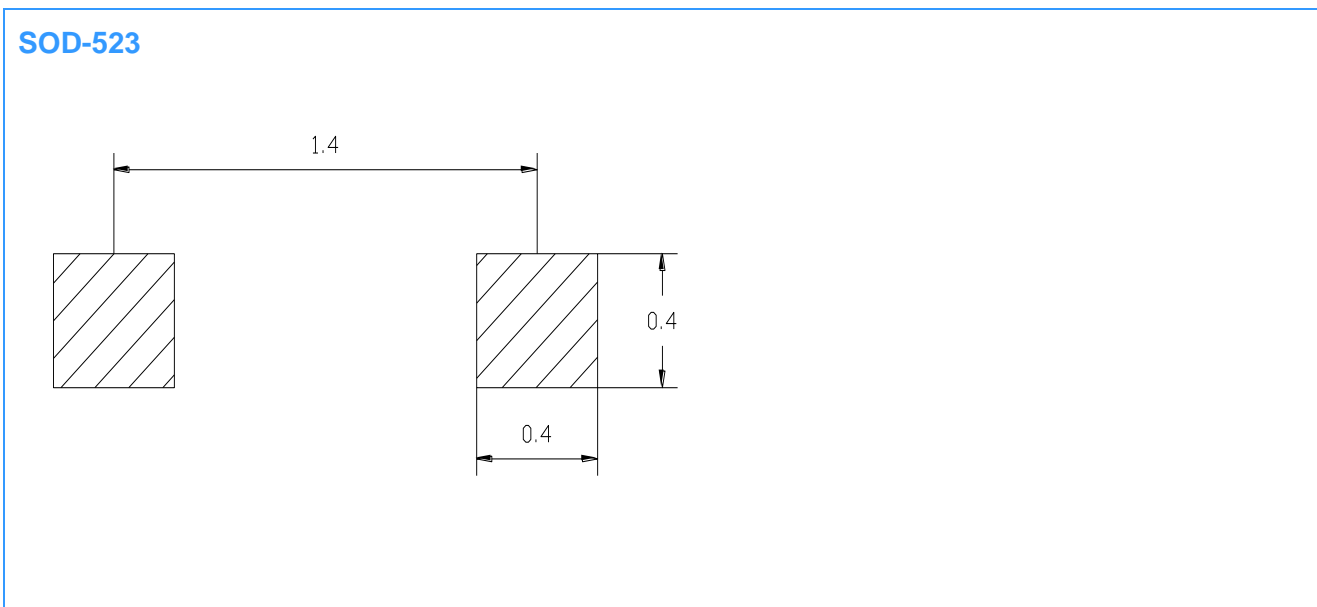

Fig 4 Power Derating Curve

Package Outline Dimensions (Unit: mm)



Package Outline Dimensions (Unit: mm)



Important Notice

Changzhou Galaxy Century Microelectronics (GME) reserves the right to make changes without further notice to any product information (copyrighted) herein to make corrections, modifications, improvements, or other changes. GME does not assume any liability arising out of the application or use of any product described herein; neither does it convey any license under its patent rights, nor the rights of others.