

PNP Epitaxial Silicon Transistor

2SA1013

FEATURES

- High BV_{CEO}
- High DC current gain
- Large continuous collector current capability
- Epitaxial planar die construction

HF

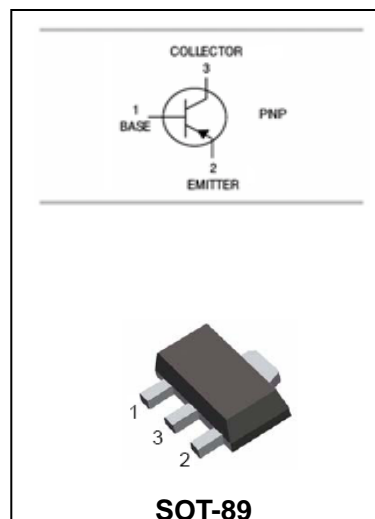

ORDERING INFORMATION

Type No.	Marking	Package Code
2SA1013	A1013	SOT-89

MAXIMUM RATING @ $T_a=25^\circ\text{C}$ unless otherwise specified

Symbol	Parameter	Value	Units
V_{CBO}	Collector-Base Voltage	-160	V
V_{CEO}	Collector-Emitter Voltage	-160	V
V_{EBO}	Emitter-Base Voltage	-6	V
I_C	Collector Current -Continuous	-1	A
I_B	Base current	-0.5	A
P_C	Collector Power Dissipation	0.5	W
$R_{\theta JA}$	Thermal Resistance Junction to Ambient Air	250	$^\circ\text{C/W}$
$R_{\theta JC}$	Thermal Resistance Junction to Case	104	$^\circ\text{C/W}$
T_J, T_{STG}	Junction and Storage Temperature	-55 to +150	$^\circ\text{C}$

PNP Epitaxial Silicon Transistor

2SA1013

ELECTRICAL CHARACTERISTICS @ Ta=25°C unless otherwise specified

Parameter	Symbol	Test conditions	MIN	TYP	MAX	UNIT
Collector-Base Voltage	V_{CBO}	$I_C=-100\mu A, I_E=0$	-160			V
Emitter-Base Voltage	V_{EBO}	$I_E=-100\mu A, I_C=0$	-6			V
Collector-emitter breakdown voltage	$V_{(BR)CEO}$	$I_C=-10mA, I_B=0$	-160			V
Collector cut-off current	I_{CBO}	$V_{CB}=-150V, I_E=0$			-1.0	μA
Emitter cut-off current	I_{EBO}	$V_{EB}=-6V, I_C=0$			-1.0	μA
DC current gain	h_{FE}	$V_{CE}=-5V, I_C=-200mA$	60		320	
Collector-emitter saturation voltage	$V_{CE(sat)}$	$I_C=-500mA, I_B=-50mA$			-1.5	V
Base-emitter voltage	V_{BE}	$I_C=-5mA, V_{CE}=-5V$			-0.75	V
Transition frequency	f_T	$V_{CE}=-5V, I_C=-200mA$	15			MHz
Collector output capacitance	C_{ob}	$V_{CB}=-10V, I_E=0, f=1MHz$			35	pF

CLASSIFICATION OF $h_{FE(1)}$

Rank	R	O	P
Range	60-120	100-200	160-320

PNP Epitaxial Silicon Transistor

2SA1013

TYPICAL CHARACTERISTICS @ Ta=25°C unless otherwise specified

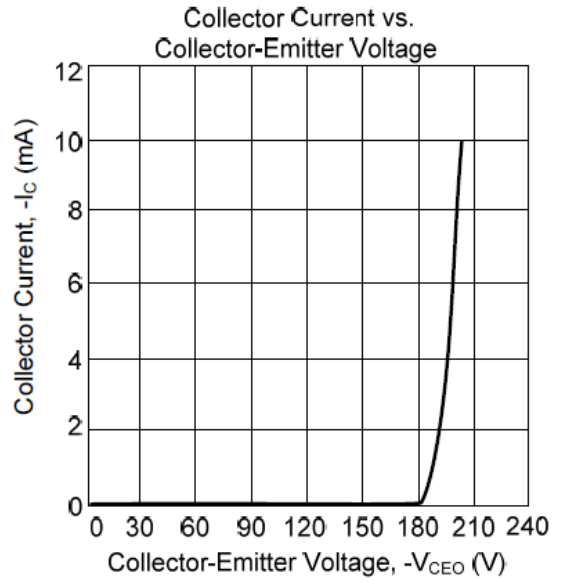
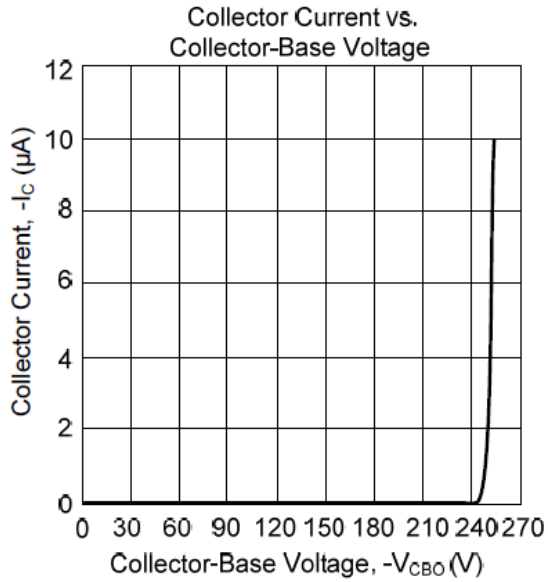

PNP Epitaxial Silicon Transistor

2SA1013

PACKAGE OUTLINE

Plastic surface mounted package

SOT-89

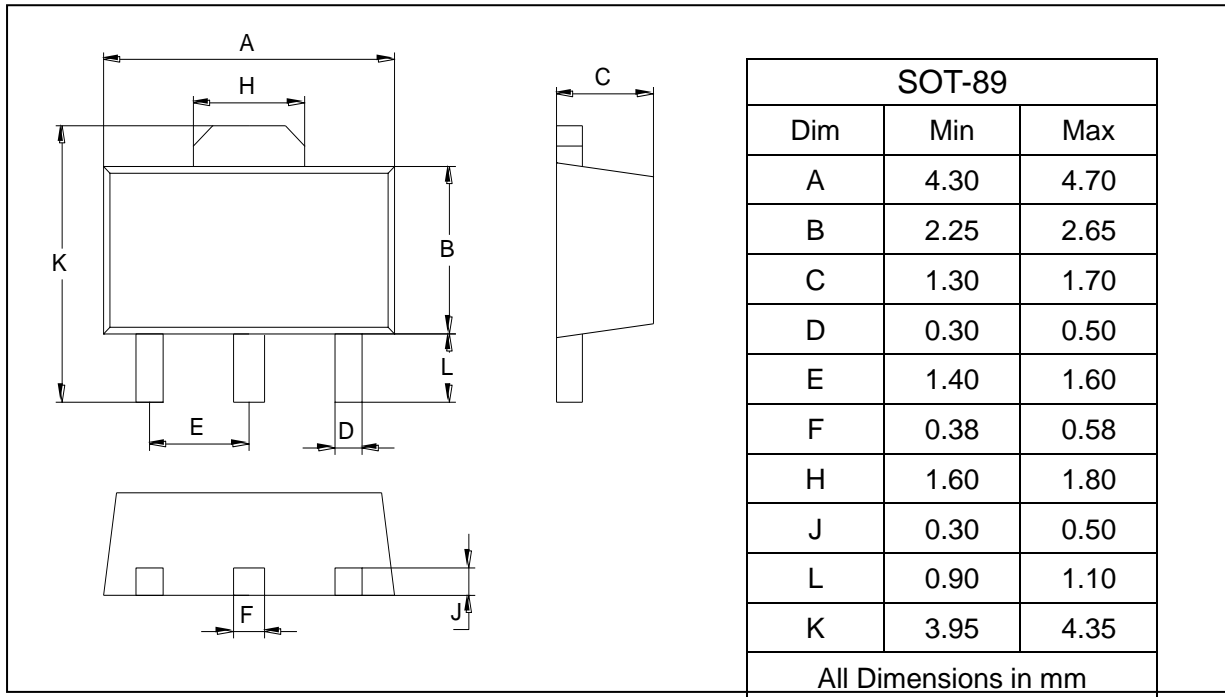

SOLDERING FOOTPRINT

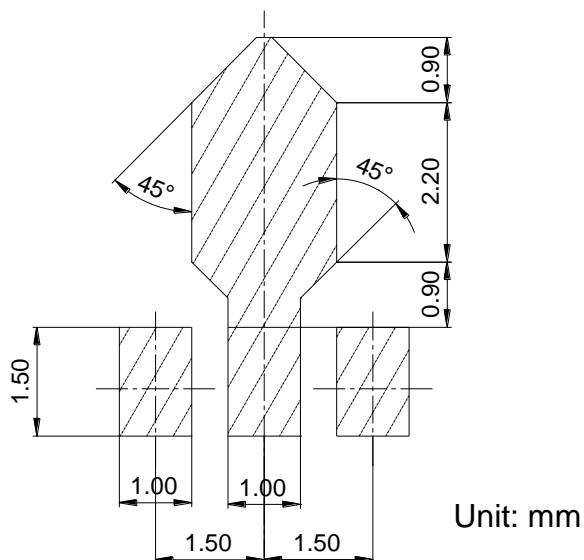

PACKAGE INFORMATION

Device	Package	Shipping
2SA1013	SOT-89	1000pcs / Tape & Reel