

Silicon Planar Epitaxial Transistor

2SA1213

FEATURES

- Low saturation voltage
- High speed switching time
- Small flat package
- Complementary to 2SC2873

HF

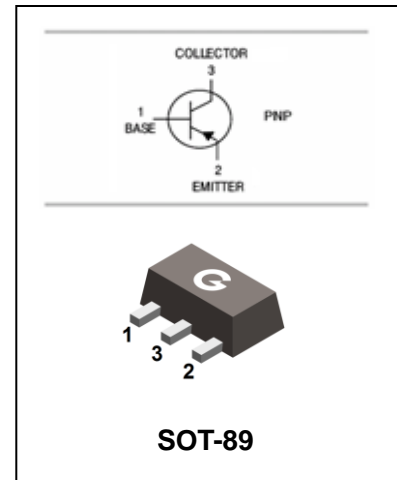

ORDERING INFORMATION

Type No.	Marking	Package Code
2SA1213	NO/NY	SOT-89

MAXIMUM RATING @ Ta=25°C unless otherwise specified

Symbol	Parameter	Value	Units
V_{CBO}	Collector-Base Voltage	-50	V
V_{CEO}	Collector-Emitter Voltage	-50	V
V_{EBO}	Emitter-Base Voltage	-5	V
I_C	Collector Current	-2	A
I_B	Base Current	-0.4	A
P_C	Collector Dissipation	500 1000(Note1)	mW
$R_{\theta JA}$	Thermal resistance junction to ambient air	75	°C/W
$R_{\theta JC}$	Junction-case thermal resistance	35	°C/W
T_j, T_{stg}	Junction and Storage Temperature	-55 to +150	°C

Note1: Mounted on ceramic substrate(250mm²*0.8t)

Silicon Planar Epitaxial Transistor

2SA1213

ELECTRICAL CHARACTERISTICS @ Ta=25°C unless otherwise specified

Parameter	Symbol	Test conditions	MIN	TYP	MAX	UNIT
Collector-emitter breakdown voltage	$V_{(BR)CEO}$	$I_C=-10mA, I_B=0$	-50			V
Collector cut-off current	I_{CBO}	$V_{CB}=-50V, I_E=0$			-0.1	μA
Emitter cut-off current	I_{EBO}	$V_{EB}=-5V, I_C=0$			-0.1	μA
DC current gain	h_{FE}	$V_{CE}=-2V, I_C=-0.5A$	70		240	
		$V_{CE}=-2V, I_C=-2.0A$	20			
Collector-emitter saturation voltage	$V_{CE(sat)}$	$I_C=-1A, I_B=-0.05A$			-0.5	V
Base-emitter saturation voltage	$V_{BE(sat)}$	$I_C=-1A, I_B=-0.05A$			-1.2	V
Transition frequency	f_T	$V_{CE}=-2V, I_C=-0.5A$		120		MHz
Collector output capacitance	C_{ob}	$V_{CB}=-10V, I_E=0, f=1MHz$		40		pF

CLASSIFICATION OF h_{FE}

Rank	O	Y
Range	70-140	120-240
Marking	NO	NY

Silicon Planar Epitaxial Transistor

2SA1213

TYPICAL CHARACTERISTICS @ $T_a=25^\circ\text{C}$ unless otherwise specified

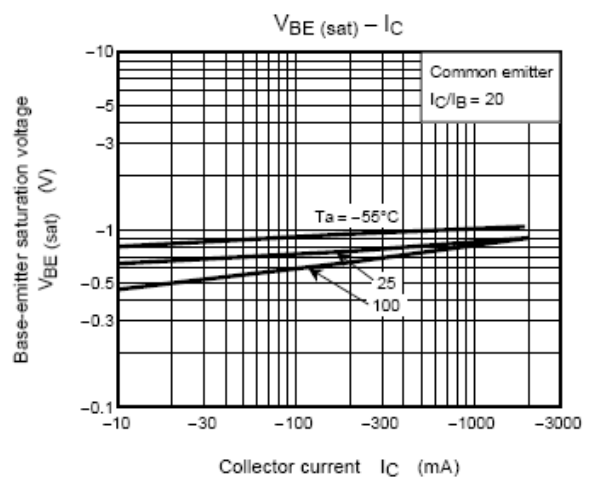
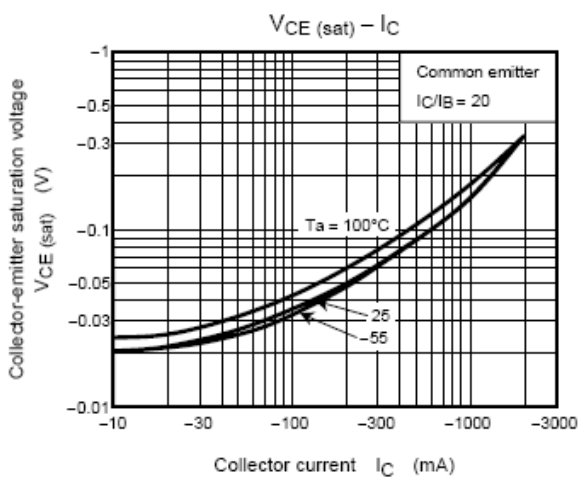
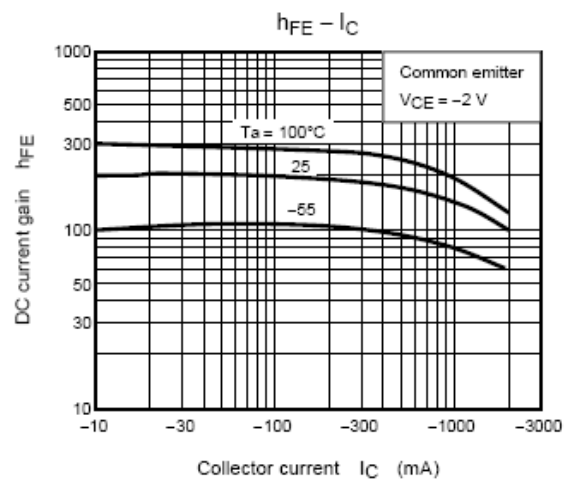
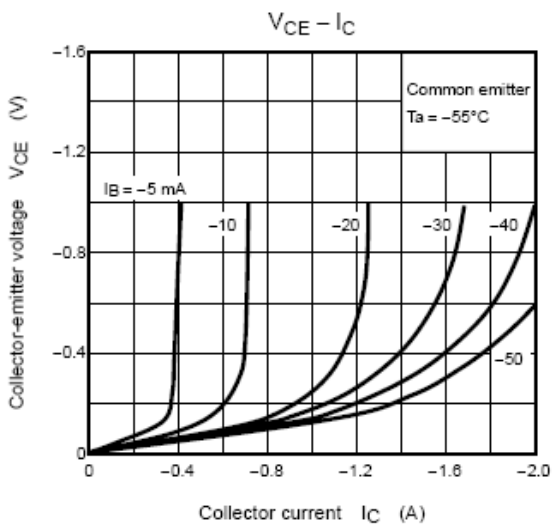
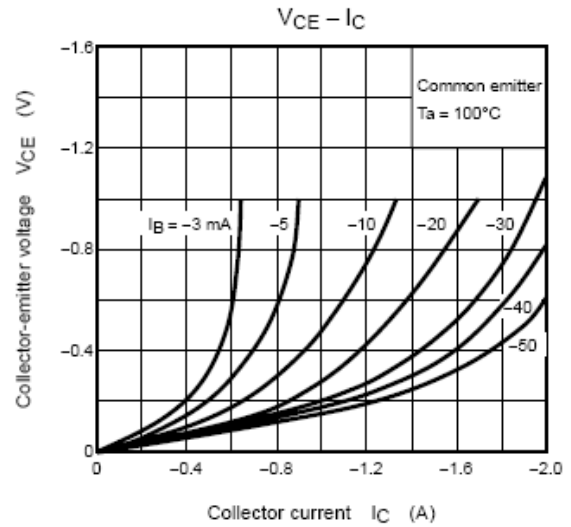
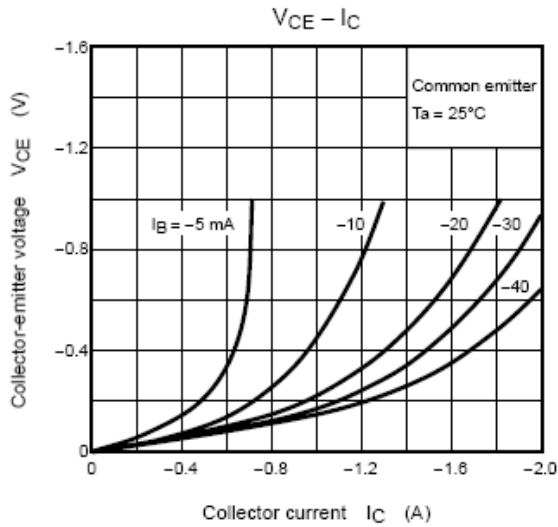

Silicon Planar Epitaxial Transistor

2SA1213

PACKAGE OUTLINE

Plastic surface mounted package

SOT-89

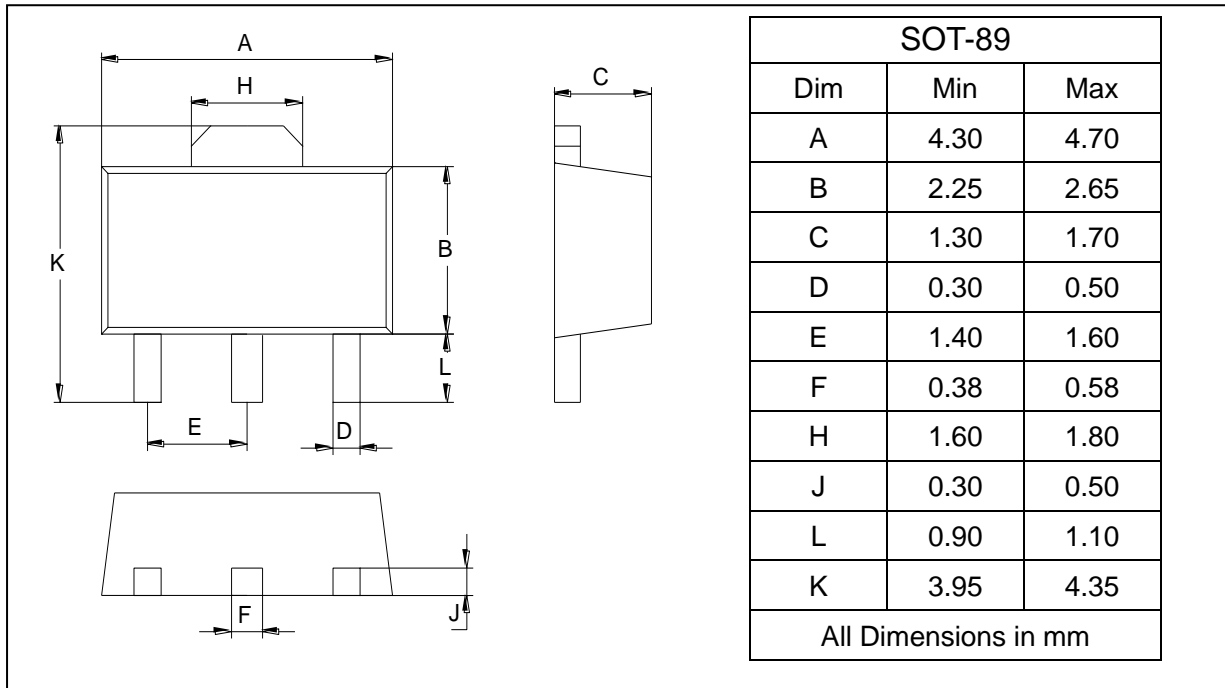

SOLDERING FOOTPRINT

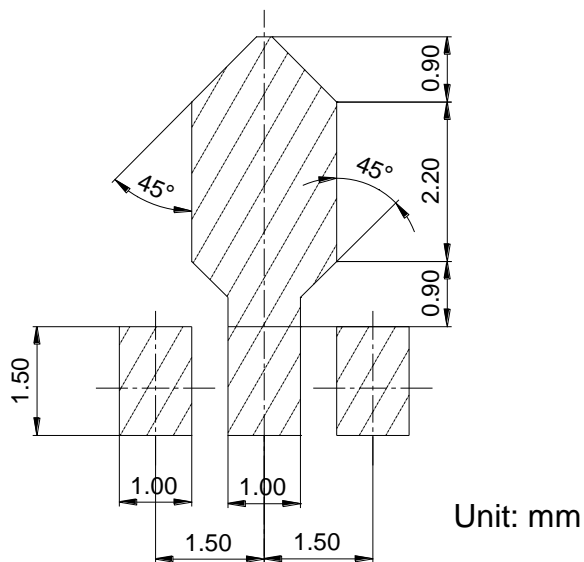

PACKAGE INFORMATION

Device	Package	Shipping
2SA1213	SOT-89	1000 pcs / Tape & Reel