

Silicon Bridge Rectifiers

3SPB50M

Features

- Glass passivated junction
- Low forward voltage drop
- High forward surge current capability
- High-temp soldering guaranteed: 260°C @ 10s.
- RoHS compliant with Halogen-free



Mechanical Data

- Case: 3SPB molded plastic
- Molding compound: UL flammability classification rating 94V-0
- Terminals: Leads solderable per MIL-STD-750

Maximum Ratings (@T_A = 25°C unless otherwise specified)

Parameter	Symbol	3SPB50M	Unit
Peak Repetitive Reverse Voltage	V _{RRM}	1000	V
RMS Reverse Voltage	V _{RMS}	700	V
DC Blocking Voltage	V _{DC}	1000	V
Maximum Average Forward Output Current	I _{F(AV)}	5.0	A
Peak Forward Surge Current, 8.3ms Single Half Sine wave	I _{FSM} @T _J = 25°C	150	A

Thermal Characteristics

Parameter	Symbol	3SPB50M	Unit
Typical Thermal Resistance *1	R _{θJA}	37	°C/W
	R _{θJC}	10.4	
	R _{θJL}	7.5	
Operating Junction Temperature Range	T _J	-55 ~ +150	°C
Storage Temperature Range	T _{STG}	-55 ~ +150	°C

Note *1: Device mounted on p.c.b. with 10 mm x 20 mm x 0.1mm copper pad area

Silicon Bridge Rectifiers

3SPB50M

Electrical Characteristics (@ $T_A = 25^\circ\text{C}$ unless otherwise specified)

Parameter	Symbol	Test Condition	Typ.	Max.	Unit	
Maximum Instantaneous Forward Voltage	V_F	$I_F = 5.0\text{A}$	-	1.15	V	
Maximum Reverse Current	I_R	Rated	@ $T_A = 25^\circ\text{C}$	-	10	μA
		V_R	@ $T_A = 125^\circ\text{C}$	-	300	

Silicon Bridge Rectifiers

3SPB50M

Ratings and Characteristic Curves (@ $T_A = 25^\circ\text{C}$ unless otherwise noted)

Fig.1 Forward Current Derating Curve

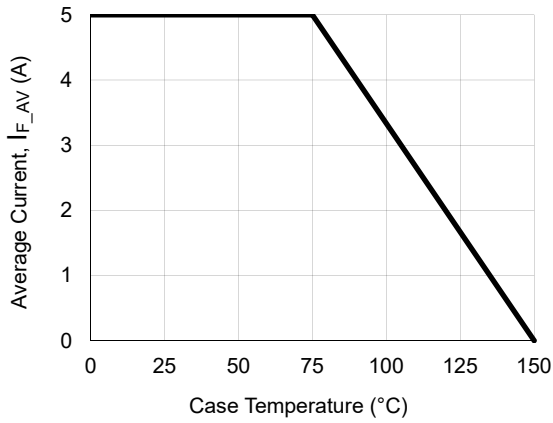

Fig.2 Surge Current Derating Curve

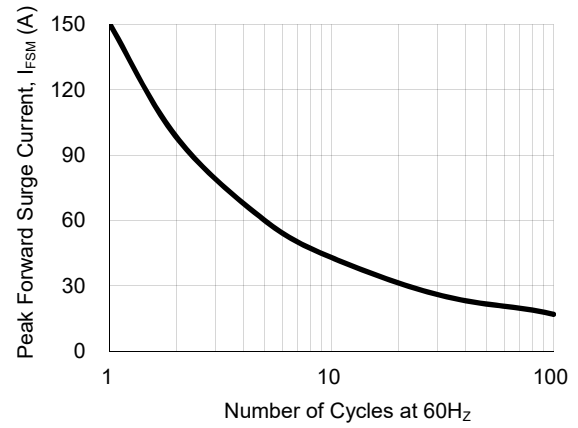

Fig.3 Typical Forward Voltage Characteristic

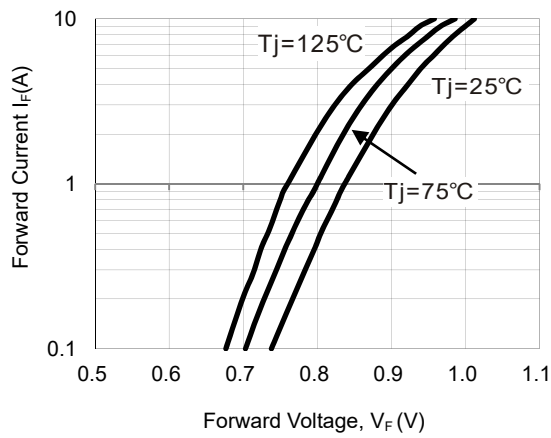
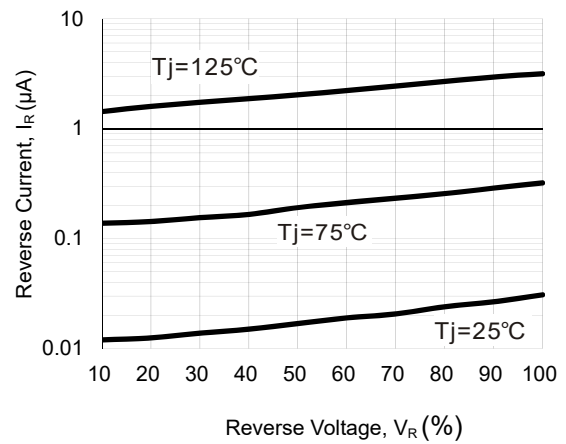

Fig.4 Typical Reverse Characteristic



Silicon Bridge Rectifiers

3SPB50M

Package Outline Dimensions (unit: mm)

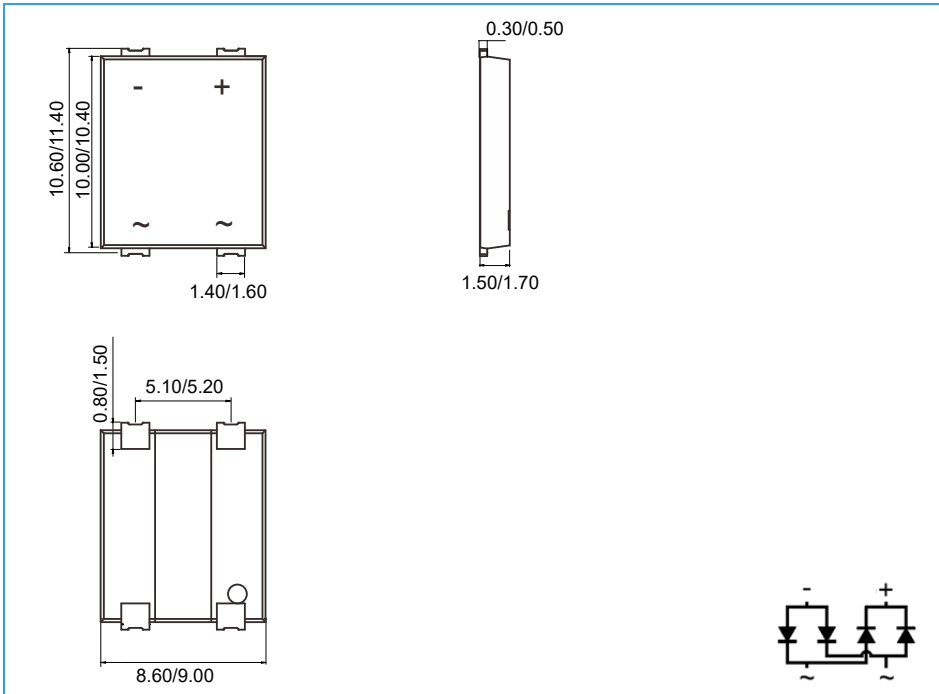

Mounting Pad Layout (unit: mm)

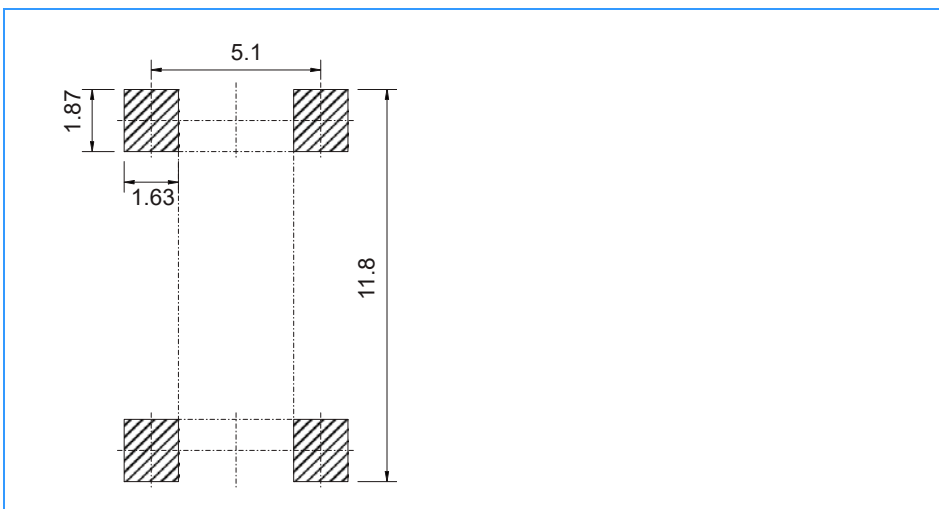

Ordering Information

Part Number	Marking	Package	Shipping Quantity
3SPB50M	3SPB50M	3SPB	1500 / Tape & Reel