

General purpose PIN Diode

BAP51-02

FEATURES

- Low diode capacitance
- Low diode forward resistance
- General purpose PIN diode in a SOD-523 ultra small SMD plastic package

HF

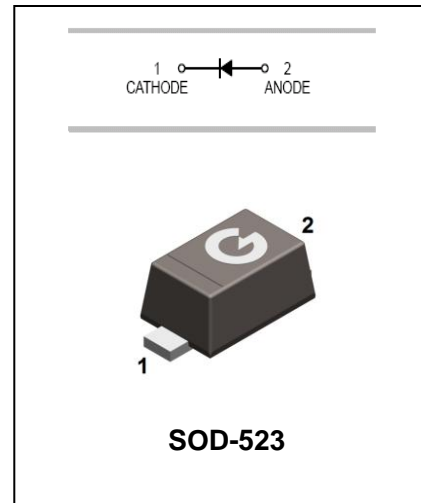

APPLICATIONS

- General RF application

ORDERING INFORMATION

Type No.	Marking	Package Code
BAP51-02	K1	SOD-523

MAXIMUM RATING @ Ta=25°C unless otherwise specified

Parameter	Symbol	Limits	Unit
Continuous reverse voltage	V_R	60	V
Continuous forward current	I_F	50	mA
Power Dissipation	P_D	500	mW
Thermal Resistance Junction to Ambient	$R_{\theta JA}$	85	°C/W
Junction temperature	T_J	-65 to +150	°C
Storage temperature	T_{stg}	-65 to +150	°C

ELECTRICAL CHARACTERISTICS @ Ta=25°C unless otherwise specified

Parameter	Symbol	Min.	Typ.	Max.	Unit	Conditions
Continuous reverse voltage	V_R	50			V	$I_R=10\mu A$
Forward voltage	V_F		0.95	1.1	V	$I_F=50mA$
Reverse current	I_R			100	nA	$V_R=50V$
Diode capacitance	C_{d1}		0.4		pF	$V_R=0V, f=1MHz$
	C_{d2}			0.55	pF	$V_R=1V, f=1MHz$
	C_{d3}			0.35	pF	$V_R=5V, f=1MHz$
Diode forward resistance	r_D			9	Ω	$I_F=0.5mA, f=100MHz$
	r_D			6.5	Ω	$I_F=1mA, f=100MHz$
	r_D			2.5	Ω	$I_F=10mA, f=100MHz$

General purpose PIN Diode

BAP51-02

TYPICAL CHARACTERISTICS @ $T_a=25^\circ\text{C}$ unless otherwise specified

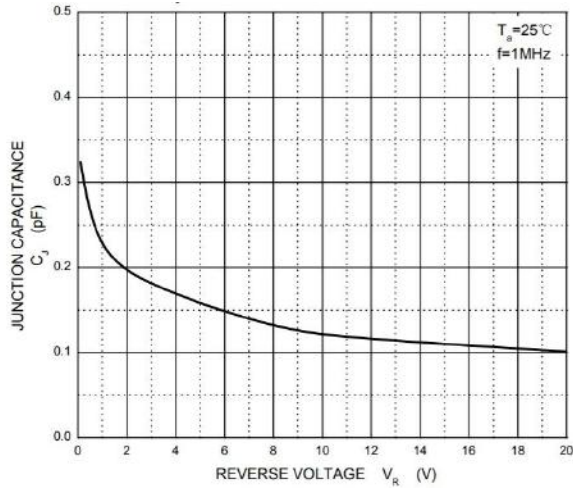

Fig.1 Diode capacitance as a function of reverse voltage

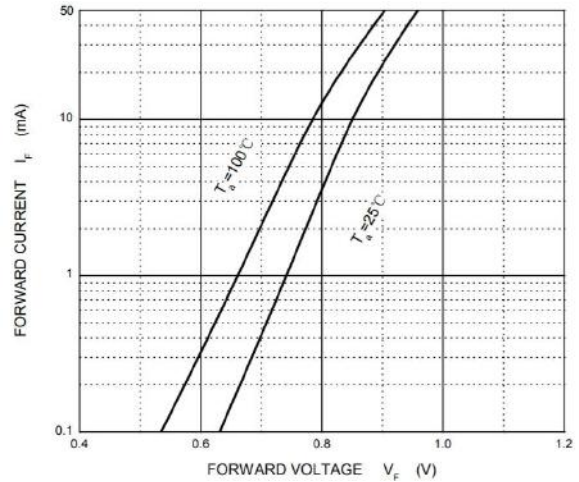

Fig.2 Forward voltage as a function of forward current

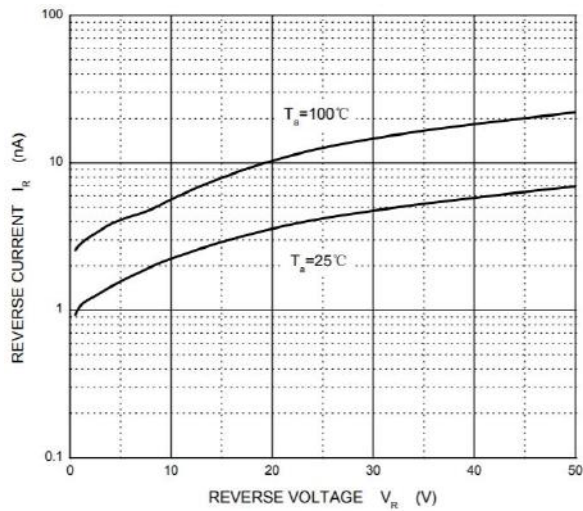

Fig.3 Reverse current as a function of reverse voltage

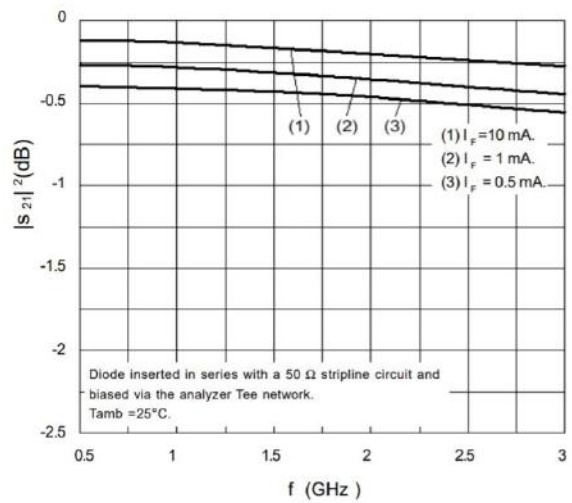

Fig.4 Insertion loss ($|S_{21}|^2$) of the diode in on-state as a function of frequency; typical values.

General purpose PIN Diode

BAP51-02

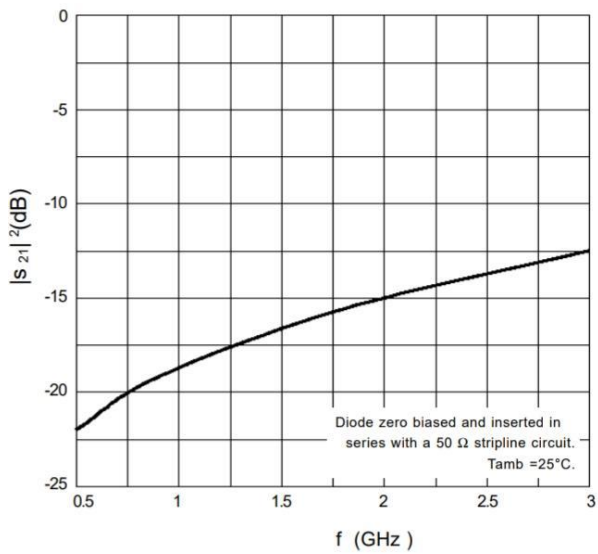

Fig.5 Isolation ($|s_{21}|^2$) of the diode in off-state as a function of frequency; typical values.

General purpose PIN Diode

BAP51-02

PACKAGE OUTLINE

Plastic surface mounted package

SOD-523

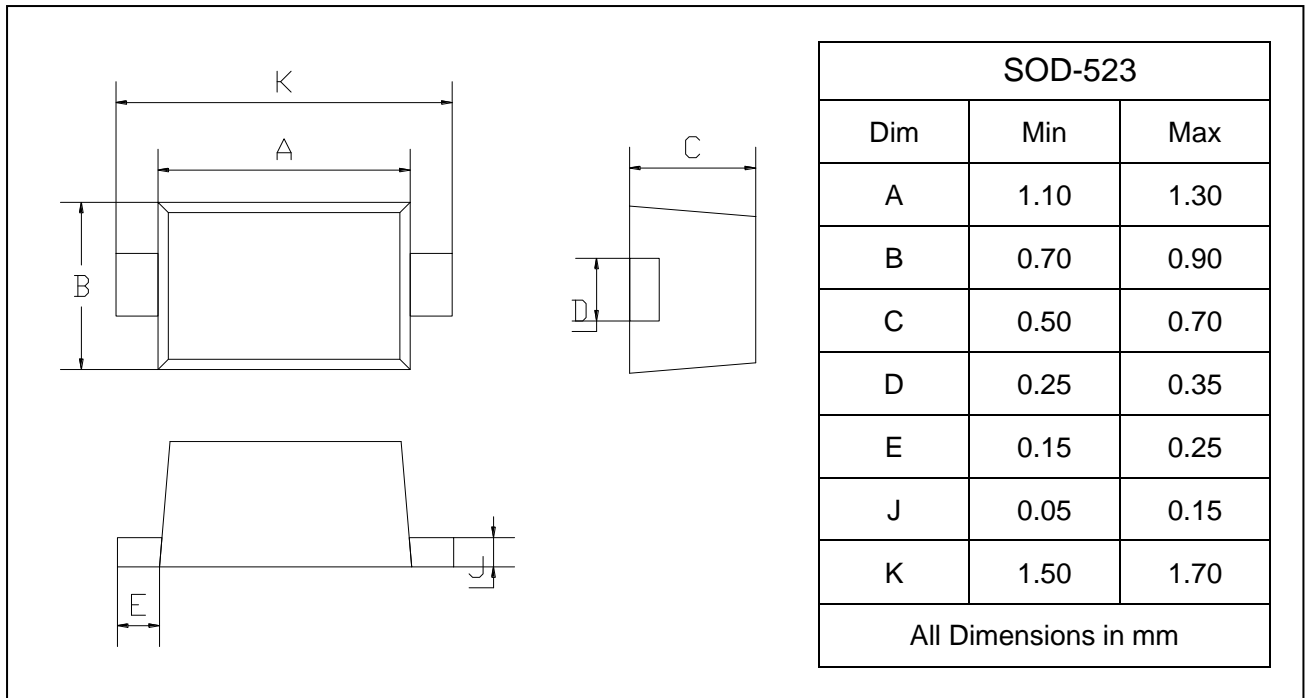

SOLDERING FOOTPRINT

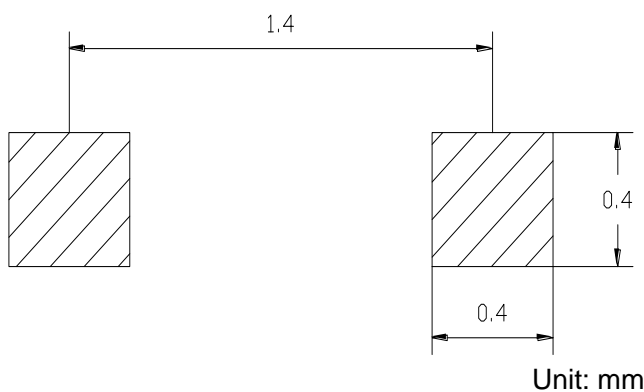

PACKAGE INFORMATION

Device	Package	Shipping
BAP51-02	SOD-523	3000 pcs / Tape & Reel