

## N-Channel Enhancement Mode Field Effect Transistor

**BL1N60F**

### FEATURES

- Ultra Low gate charge (typical 5.0nC)
- Low reverse transfer capacitance (CRSS = typical 3.0 pF)
- Fast switching capability
- Avalanche energy specified
- Improved dv/dt capability, high ruggedness

**HF**

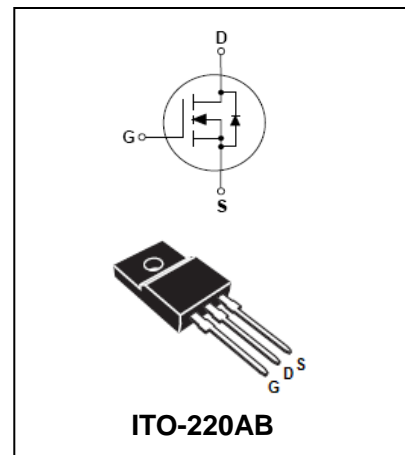

### Ordering Information

Part Number	Package	Shipping	Marking Code
BL1N60F	ITO-220AB	50 pcs / Tube	1N60F

### MAXIMUM RATING operating temperature range applies unless otherwise specified

Symbol	Parameter	Value	Units
$V_{DS}$	Drain-Source voltage	600	V
$V_{GS}$	Gate -Source voltage	$\pm 30$	V
$I_D$	Continuous Drain current $T_C=25^\circ\text{C}$	1.2	A
	Continuous Drain current $T_C=100^\circ\text{C}$	0.76	A
$E_{AS}$	Single Pulse Avalanche Energy(Note3)	50	mJ
$E_{AR}$	Avalanche Energy, Repetitive(Note2)	4.0	mJ
$I_{AR}$	Avalanche Current(Note2)	1.2	A
ISD	Continuous Drain-Source Current	1.2	A
ISM	Pulsed Drain-Source Current	4.8	A
dv/dt	Peak Diode Recovery dv/dt(Note4)	4.5	V/ns
$P_D$	Power Dissipation	40	W
	Derating Fcator above $25^\circ\text{C}$	0.32	W/ $^\circ\text{C}$
$R_{\theta JC}$	Junction-to-Case	4	$^\circ\text{C}/\text{W}$
$R_{\theta JA}$	Junction-to-Ambient	54	$^\circ\text{C}/\text{W}$
$T_J, T_{stg}$	Junction and Storage Temperature	-55 to +150	$^\circ\text{C}$
$T_L$	Maximum Temperature for Soldering	+150	$^\circ\text{C}$

## N-Channel Enhancement Mode Field Effect Transistor

**BL1N60F**

Note: 1. Absolute maximum ratings are those values beyond which the device could be permanently damaged.

Absolute maximum ratings are stress ratings only and functional device operation is not implied.

2. Repetitive Rating: Pulse Width Limited by Maximum Junction Temperature
3. L=64mH, IAS=1.2A, VDD=50V, RG=25Ω, Starting TJ =25°C
4. ISD≤1.2A, di/dt ≤ 200A/μs, VDD ≤ BVDSS, Starting TJ =25°C

### ELECTRICAL CHARACTERISTICS

Parameter	Symbol	Test conditions	MIN	TYP	MAX	UNIT
Drain-Source Breakdown Voltage	$V_{(BR)DSS}$	$V_{GS}=0V, I_D=250\mu A$	600	-	-	V
Bvdss Temperature Coefficient	$\frac{\Delta BV_{DSS}}{\Delta T_J}$	$I_D=250mA,$	-	0.4	-	V/°C
Gate Threshold Voltage	$V_{GS(TH)}$	$V_{DS}=V_{GS}, I_D=250mA$	2		4	V
Drain to Source Leakage Current	$I_{DSS}$	$V_{DS}=600V, V_{GS}=0V$	-	-	10	μA
		$V_{DS}=480V, T_a=125^\circ C$			100	
Static drain-Source on-resistance	$R_{DS(ON)}$	$V_{GS}=10V, I_D=0.6A$	-	9.3	11.5	Ω
Gate-body Leakage	$I_{GSS}$	$V_{GS}=\pm 30V$			±	nA
Forward Reverse					100	
Forward Transconductance	$g_{fs}$	$V_{DS}=50V, I_D=0.6A$	-	0.9	-	S
Input Capacitance	$C_{iss}$	$V_{GS}=0V, V_{DS}=25V$ $f=1.0MHz$	-	120	150-	pF
Output Capacitance	$C_{oss}$		-	20	25	
Reverse Transfer Capacitance	$C_{rss}$		-	3.0	4.0	
Turn-on Delay Time	$t_{d(ON)}$	$I_D=1.2A, V_{DD}=300V$ $V_{GS}=10V$	-	5	20	ns
Rise Time	$t_r$		-	25	60	
Turn-Off Delay Time	$t_{d(OFF)}$		-	7	25	
Fall Time	$t_f$		-	25	60	
Total Gate Charge	$Q_g$	$I_D=1.2A, V_{DD}=480V$ $V_{GS}=10V$	-	5.0	6.0	nC
Gate to Source Charge	$Q_{gs}$		-	1.0		
Gate to Drain ("Miller") Charge	$Q_{gd}$		-	2.6		
Reverse Recovery Time	$t_{rr}$	$I_S=1.2A, T_J=25^\circ C$ $dI_F/dt=100A/us,$ $V_{GS}=0V$	-	160	-	ns
Reverse Recovery Charge	$Q_{rr}$		-	0.3	-	nC

Note: 1. Pulse Test: Pulse Width ≤300μs, Duty Cycle≤2%

2. Essentially Independent of Operating Temperature

**N-Channel Enhancement Mode Field Effect Transistor**

**BL1N60F**

**PACKAGE OUTLINE**

Plastic surface mounted package

ITO-220AB

