

4 PIN DIP PHOTOTRANSISTOR PHOTOCOUPLER

BL816 Series

FEATURES

- Current transfer ratio
(CTR: MIN.50%at $I_F=5mA, V_{CE}=5V$)
- High isolation voltage between inputc
and output ($V_{iso}=5000V$ rms)
- High collector-emitter voltage ($V_{CEO}:70V$)
- Pb free and ROHS compliant
- Recognized by UL, file No. E340048

HF

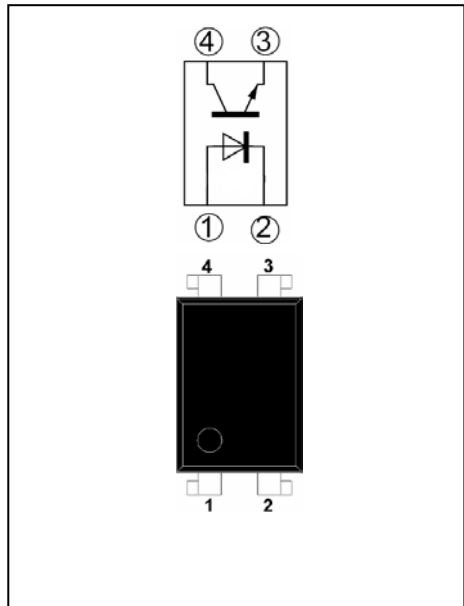

APPLICATIONS

- Programmable controllers
- System appliances,measuring instruments
- Signal transmission between circuits of different potentials
- And impedances

MAXIMUM RATING @ $T_a=25^{\circ}C$ unless otherwise specified

Parameter		Symbol	Rating	Unit
Input	Forward Current	I_F	50	mA
	Peak forward Current (Note 1)	I_{FM}	1	A
	Reverse Voltage	V_R	6	V
	Power Dissipation	P	70	mW
Output	Collector-emitter voltage	V_{CEO}	70	V
	Emitter-collector voltage	V_{ECO}	6	V
	Collector Current	I_C	50	mA
	Collector power dissipation	P_C	150	mW
Total power dissipation		P_{tot}	200	mW
Isolation voltage (Note 2)		V_{iso}	5000	V_{rms}
Rated repetitive peak isolation voltage		V_{IORM}	630	V
Thermal resistance,junction to ambient air		$R_{\theta JA}$	430	$^{\circ}C/W$
Thermal Resistance Junction-to-Case		$R_{\theta JC}$	350	$^{\circ}C/W$
Operating temperature		T_{opr}	-30 to +100	$^{\circ}C$
Storage temperature		T_{stg}	-55 to +125	$^{\circ}C$
Soldering temperature (Note 3)		T_{sol}	260	$^{\circ}C$

Note 1: Pulse width \leq 100ms, Duty ratio : 0.001

2: 40 to 60% RH, AC for 1 minute

3: For 10 seconds

4 PIN DIP PHOTOTRANSISTOR PHOTOCOUPLER
BL816 Series
ELECTRICAL CHARACTERISTICS @ Ta=25°C unless otherwise specified

Parameter		Symbol	Conditions	MIN.	TYP.	MAX.	Unit
Input	Forward voltage	V_F	$I_F=20mA$	-	1.2	1.4	V
	Peak forward voltage	V_{FM}	$I_{FM}=0.5A$	-	-	3.0	V
	Reverse current	I_R	$V_R=4V$	-	-	10	μA
	Terminal capacitance	C_t	$V=0, f=1kHz$	-	30	250	pF
Output	Collector dark current	I_{CEO}	$V_{CE}=20V, I_F=0$	-	-	10^{-7}	A
	Collector-Emitter breakdown voltage	BV_{CEO}	$I_C=0.1mA, I_F=0$	80	-	-	V
	Emitter-Collector breakdown voltage	BV_{ECO}	$I_E=10\mu A, I_F=0$	6	-	-	V
Transfer Characteristics	Current transfer ratio (Note 4)	CTR	$I_F=5mA, V_{CE}=5V$	50	-	600	%
	Collector-emitter saturation voltage	$V_{CE(sat)}$	$I_F=20mA, I_C=1mA$	-	0.1	0.2	V
	Isolation resistance	R_{ISO}	DC500V, 40 to 60%RH	5×10^{10}	10^{11}	-	Ω
	Floating capacitance	C_f	$V=0, f=1MHz$	-	0.6	1.0	pF
	Cut-off frequency	f_c	$V_{CE}=5V, I_C=2mA,$ $R_L=100\Omega, -3dB$	-	80	-	KHz
	Response time	Rise time	t_r	$V_{CE}=2V, I_C=2mA$	-	4	18
Fall time		t_f	$R_L=100\Omega$	-	3	18	μs

Note 4: Classification table of current transfer ratio is shown below.

Rank Table of Current Transfer Ratio CTR

Model No.	RANK MARK	MIN.(%)	MAX.(%)
BL816A	A	80	160
BL816B	B	130	260
BL816C	C	200	400
BL816D	D	300	600
BL816	A,B,C,D or No mark	50	600

4 PIN DIP PHOTOTRANSISTOR PHOTOCOUPLER

BL816 Series

TYPICAL CHARACTERISTICS @ $T_a=25^\circ\text{C}$ unless otherwise specified

Fig. 1 Forward Current vs. Ambient Temperature

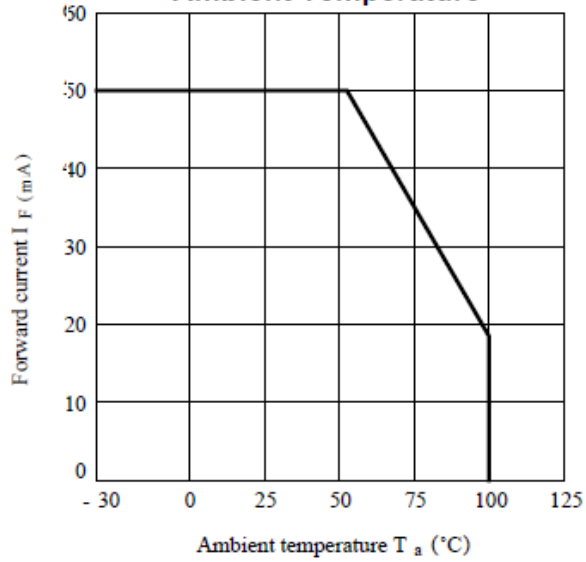

Fig. 2 Collector Power Dissipation VS. Ambient Temperature

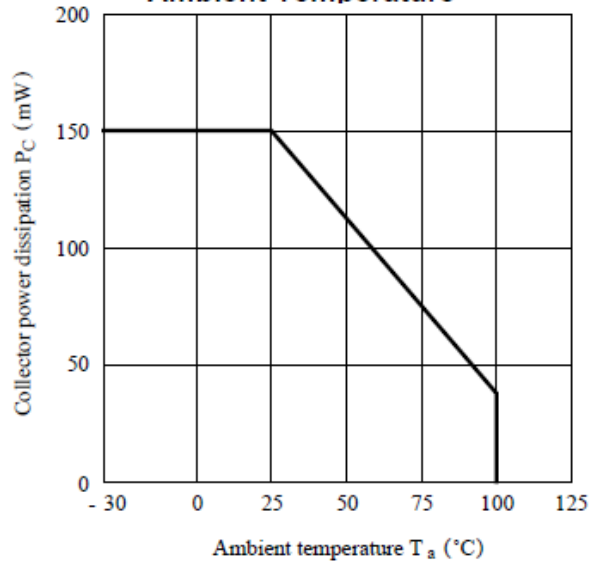
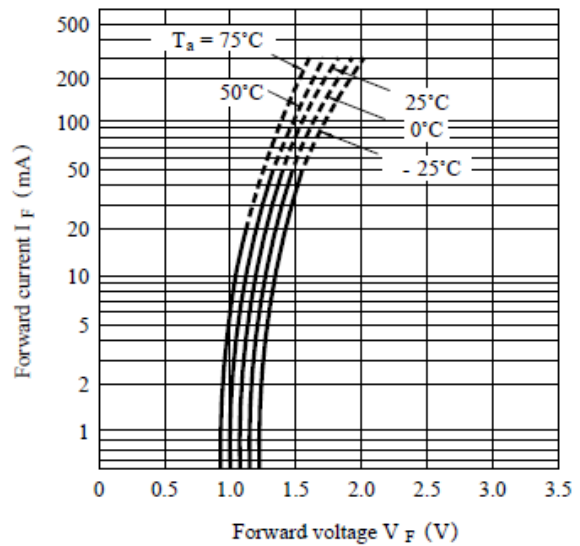
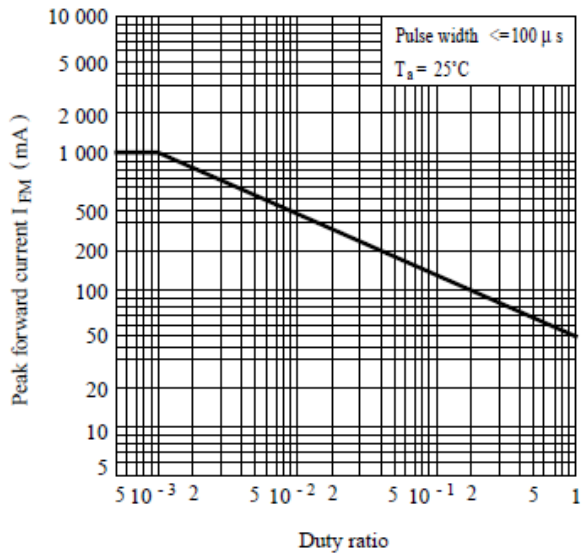

Fig. 3 Peak Forward Current vs. Duty Ratio **Fig. 4 Forward Current vs. Forward Voltage**



4 PIN DIP PHOTOTRANSISTOR PHOTOCOUPLER

BL816 Series

Fig. 5 Current Transfer Ratio vs. Forward Current

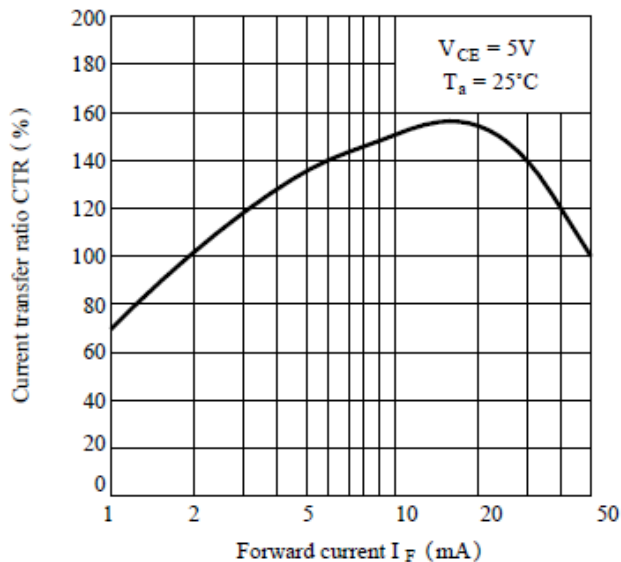

Fig. 6 Collector Current vs. Collector-emitter Voltage

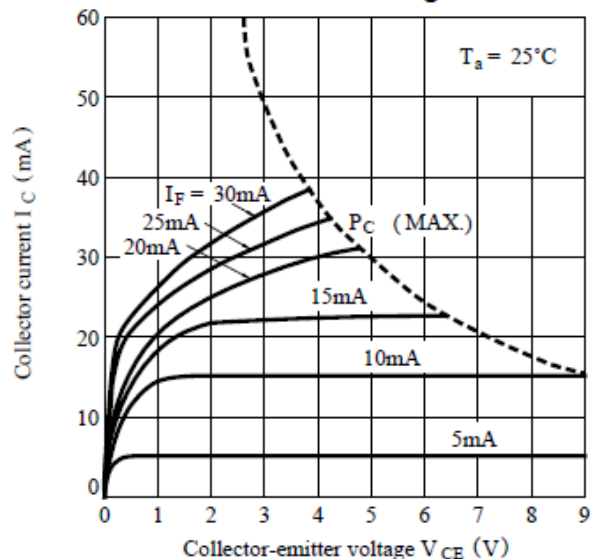

Fig. 7 Relative Current Transfer Ratio vs. Ambient Temperature

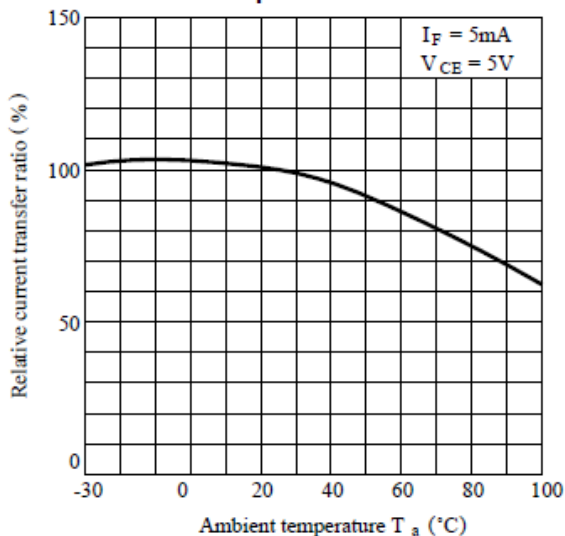
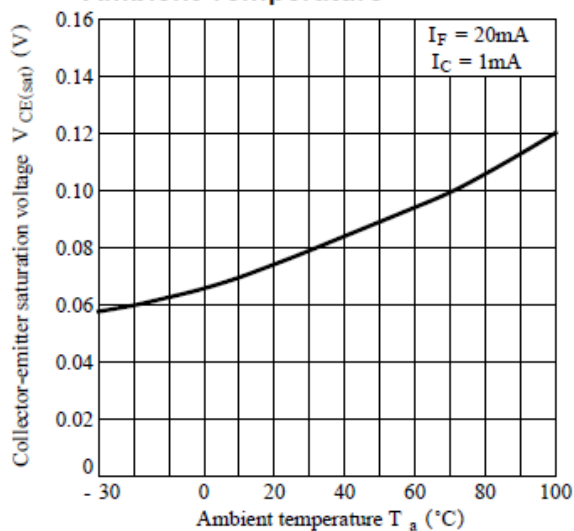

Fig. 8 Collector-emitter Saturation Voltage vs. Ambient Temperature



4 PIN DIP PHOTOTRANSISTOR PHOTOCOUPLER

BL816 Series

Fig. 9 Collector Dark Current vs. Ambient Temperature

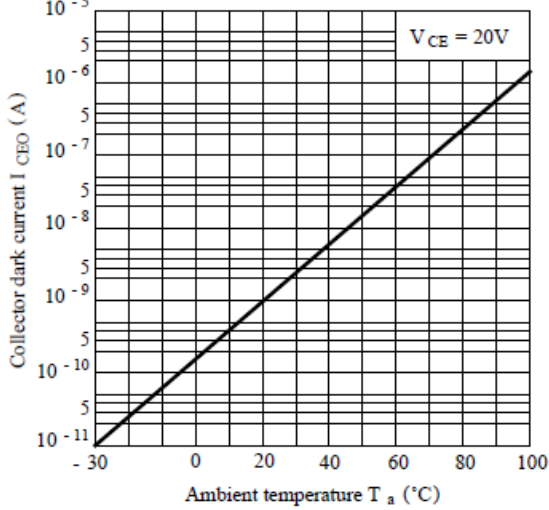

Fig.10 Response Time vs. Load Resistance

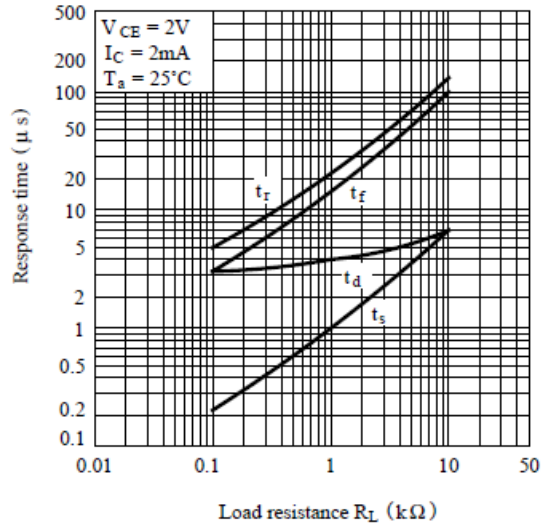

Fig.11 Frequency Response

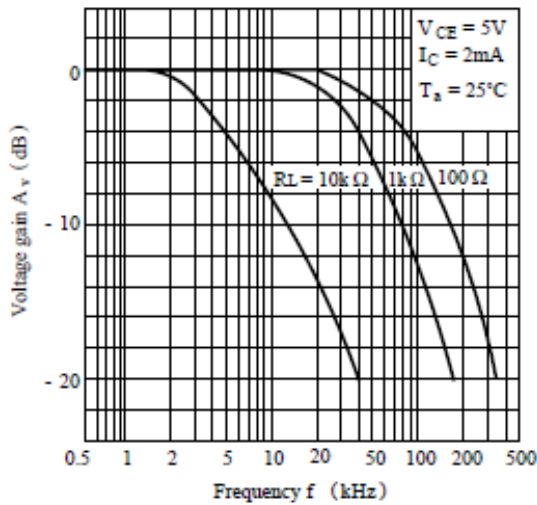
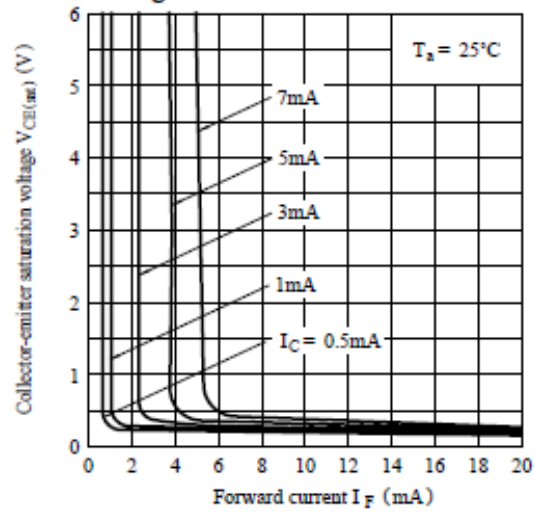
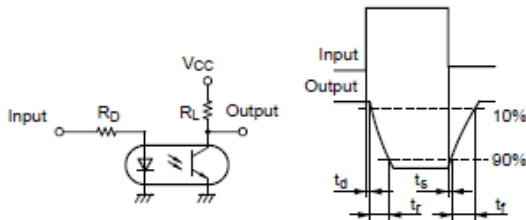

Fig.12 Collector-emitter Saturation Voltage vs. Forward Current



Test Circuit for Response Time



Test Circuit for Frequency Response

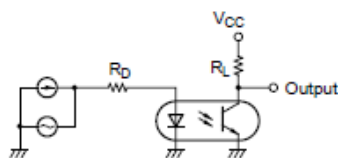

4 PIN DIP PHOTOTRANSISTOR PHOTOCOUPLER

BL816 Series

Package Dimensions (All Dimensions in mm)

BL816

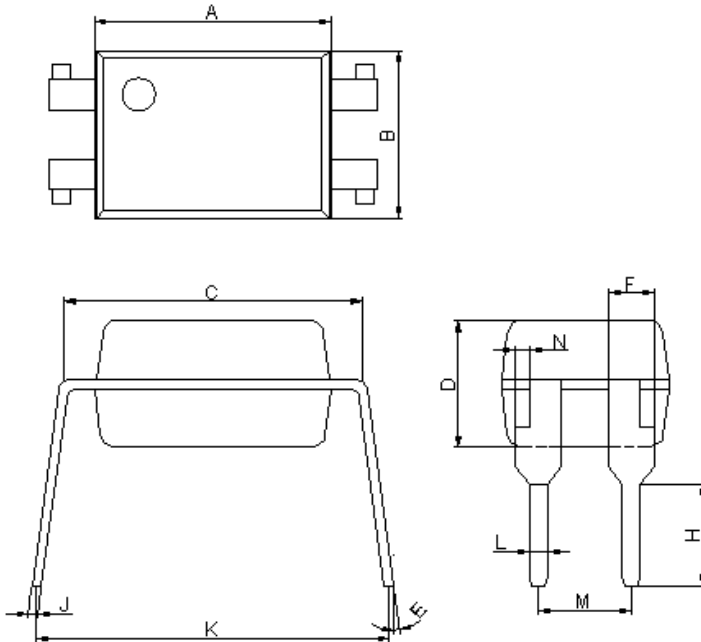

Dim	Min	Max
A	6.40	6.60
B	4.50	4.70
C	7.90	8.30
D	3.28	3.68
E	2°	8°
F	1.15	1.35
H	2.70	2.90
J	0.20	0.30
K	8.86	9.31
L	0.40	0.60
M	2.44	2.64
N	0.30	0.50

BL816M

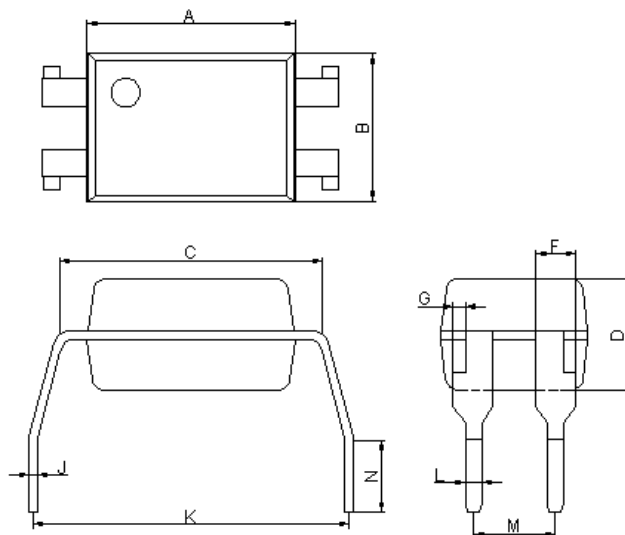

Dim	Min	Max
A	6.40	6.60
B	4.50	4.70
C	7.90	8.30
D	3.28	3.68
F	1.15	1.35
G	0.30	0.50
J	0.20	0.30
K	9.86	10.46
L	0.40	0.60
M	2.44	2.64
N	2.40	2.90

4 PIN DIP PHOTOTRANSISTOR PHOTOCOUPLER

BL816 Series

BL816S

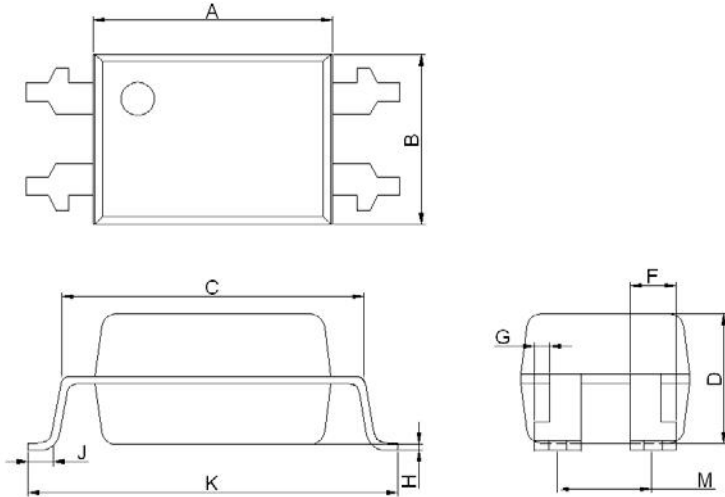

Dim	Min	Max
A	6.40	6.60
B	4.50	4.70
C	7.90	8.30
D	3.28	3.68
F	1.15	1.35
G	0.30	0.50
H	0.00	0.20
J	0.9	1.2
K	9.80	10.30
M	2.49	2.69

Ordering Information

Part Number	Package	Application part number
BL816	4-pin DIP	BL816
BL816S	4-pin (tape and reel packaging)	
BL816M	4-pin (leads with 0.4" spacing)	

SOLDERING FOOTPRINT

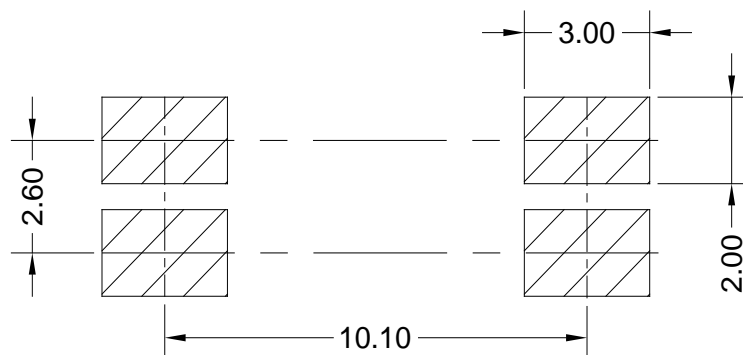

UNIT:mm