

Features

- Current transfer ratio
(CTR: 50~600% at $I_F=5\text{mA}$, $V_{CE}=5\text{V}$)
- High collector-emitter voltage: $V_{CEO} = 350\text{V}$
- High isolation voltage between input and output: $V_{iso} = 5000\text{V rms}$
- Creepage distance > 7.62mm

HF

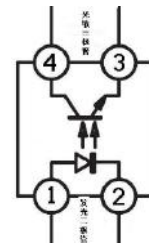

Applications

- Programmable controllers
- System appliances, measuring instruments
- Telecommunication equipments
- Home appliances, such as fan heaters, etc.
- Signal transmission between circuits of different potentials and impedances



Mechanical Data

- Molding Compound, UL Flammability Classification Rating 94V-0.
- Terminals: Matte Tin Plated Leads, Solderable per MIL-STD-202, Method 208

Ordering Information

Part Number	Package	Shipping Quantity
BL817T	DIP-4L	100pcs / Tube
BL817T	DIP-4L-M	100pcs / Tube
BL817T	SOP-4L	2000pcs / Tape & Reel

Maximum Ratings (@ $T_A = 25^\circ\text{C}$ unless otherwise specified)

Parameter		Symbol	Value	Unit
Input	Forward Current	I_F	60	mA
	Peak Forward Current *1	I_{FM}	1	A
	Reverse Voltage	V_R	6	V
	Power Dissipation	P_D	100	mW
Output	Collector Power Dissipation	P_C	150	mW
	Collector Current	I_C	50	mA
	Collector-Emitter Voltage	V_{CEO}	350	V
	Emitter-Collector Voltage	V_{ECO}	7	V

Thermal Characteristics

Parameter	Symbol	Value	Unit
Total Power Dissipation	P_{TOT}	200	mW
Isolation Voltage ^{*2}	V_{ISO}	5000	V rms
Rated Impulse Isolation Voltage	V_{IOTM}	6000	V
Rated Repetitive Peak Isolation Voltage	V_{IORM}	630	V
Thermal Resistance Junction-to-Air	$R_{\theta JA}$	430	°C/W
Thermal Resistance Junction-to-Case	$R_{\theta JC}$	350	°C/W
Operating Temperature	T_{OPR}	-40 ~ +100	°C
Storage Temperature Range	T_{STG}	-55 to +125	°C
Soldering Temperature ^{*3}	T_{SOL}	260	°C

Notes:

1. Pulse width $\leq 1\mu s$, Duty ratio: 0.001
2. 40 to 60% RH, AC for 1 minute
3. For 10 seconds
4. Current conversion ratio = $I_C / I_F \times 100\%$

Electrical Characteristics (@ $T_A = 25^\circ C$ unless otherwise specified)

Parameter		Symbol	Test Condition	Min.	Typ.	Max.	Unit
Input	Forward Voltage	V_F	$I_F = 20mA$	-	1.2	1.4	V
	Peak Forward Voltage	V_{FM}	$I_{FM} = 0.5A$	-	-	3	V
	Reverse Current	I_R	$V_R = 5V$	-	-	5	μA
	Terminal Capacitance	C_T	$V_R = 0V, f = 1kHz$	-	30	250	pF
Output	Collector-Emitter Dark Current	I_{CEO}	$V_{CE} = 200V, I_F = 0mA$	-	-	100	nA
	Collector-Emitter Breakdown Voltage	BV_{CEO}	$I_C = 0.1mA, I_F = 0mA$	350	-	-	V
	Emitter-Collector Breakdown Voltage	BV_{ECO}	$I_E = 10\mu A, I_F = 0mA$	7	-	-	V
Transfer Characteristics	Collector Current	I_C	$I_F = 5mA, V_{CE} = 5V$	2.5	-	30	mA
	Current Transfer Ratio ^{*4}	CTR	$I_F = 5mA, V_{CE} = 5V$	50	-	600	%
	Collector-Emitter Saturation Voltage	$V_{CE(sat)}$	$I_F = 20mA, I_C = 1mA$	-	0.1	0.3	V
	Isolation Resistance	R_{IO}	$V_{IO} = 500Vdc$ 40~60% R.H.	5×10^{10}	1×10^{11}	-	Ω
	Floating Capacitance	C_{IO}	$V_{IO} = 0V, f = 1MHz$	-	0.6	1	pF
	Cut-off Frequency	f_c	$V_{CE} = 5V, I_C = 2mA$ $R_L = 100\Omega, -3dB$	-	50	-	kHz
	Rise Time	t_r	$V_{CE} = 2V$ $I_C = 2mA$	-	4	10	μs
Fall Time	t_f	$R_L = 100\Omega$	-	5	12		

Ratings and Characteristics Curves (@ $T_A = 25^\circ\text{C}$ unless otherwise specified)

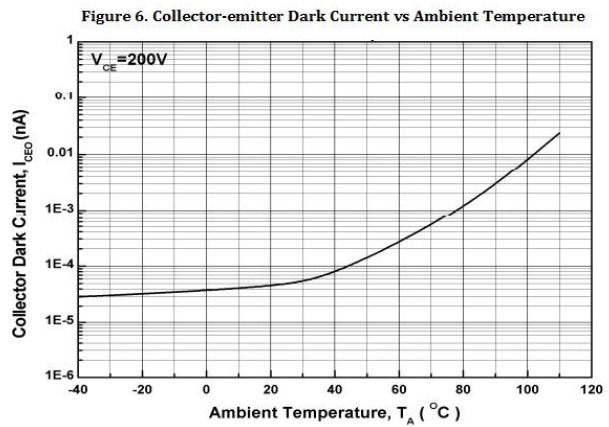
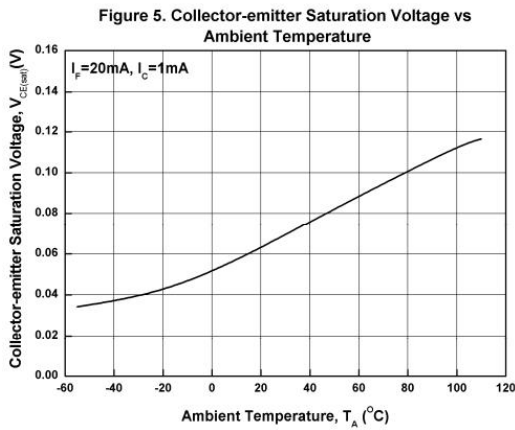
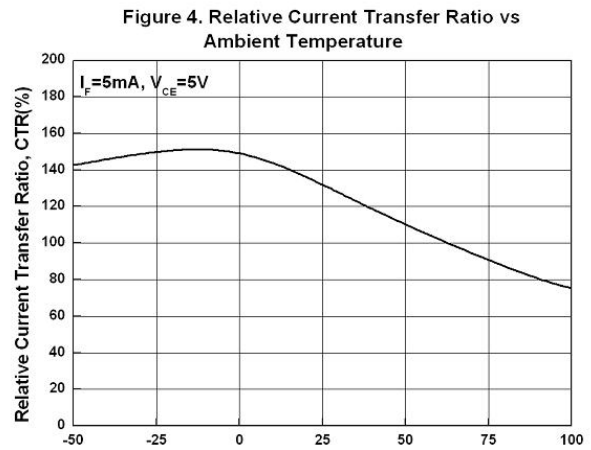
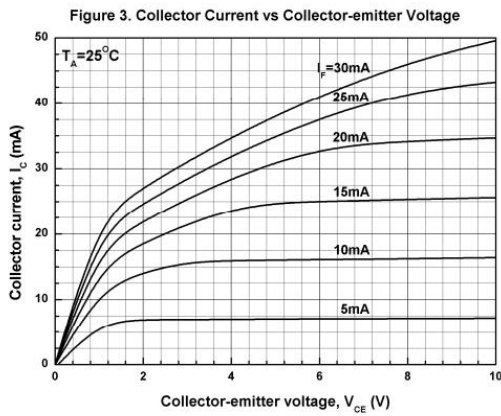
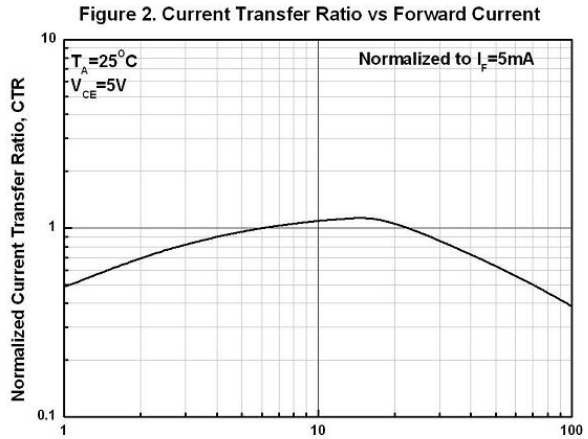
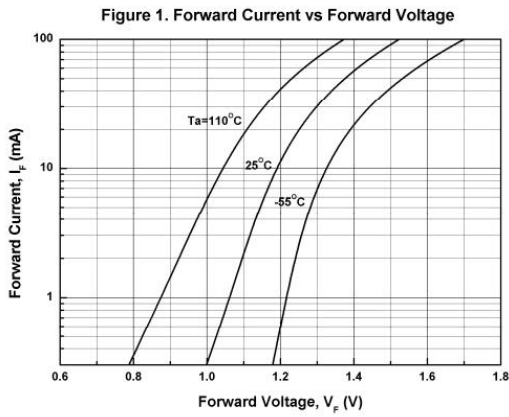

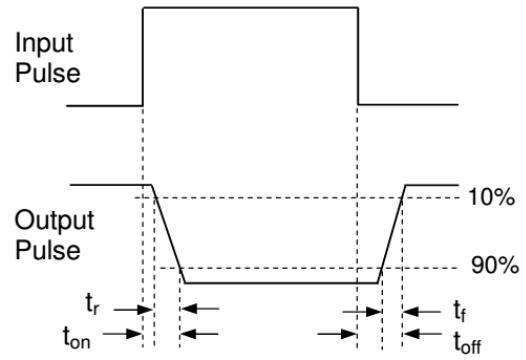
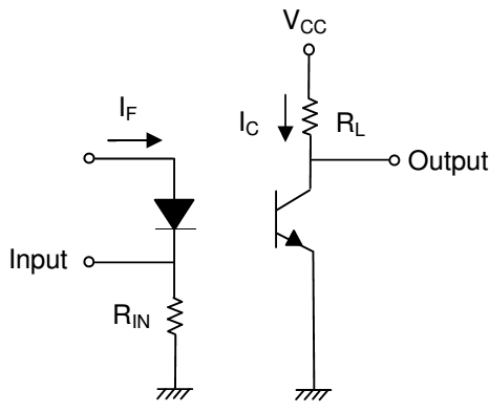
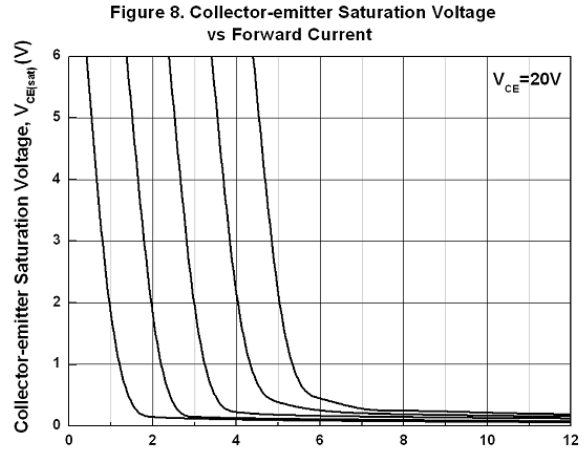
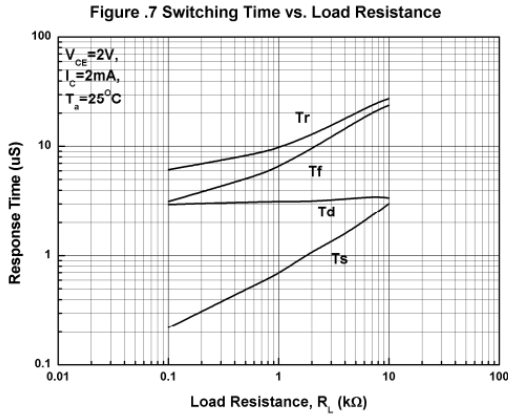
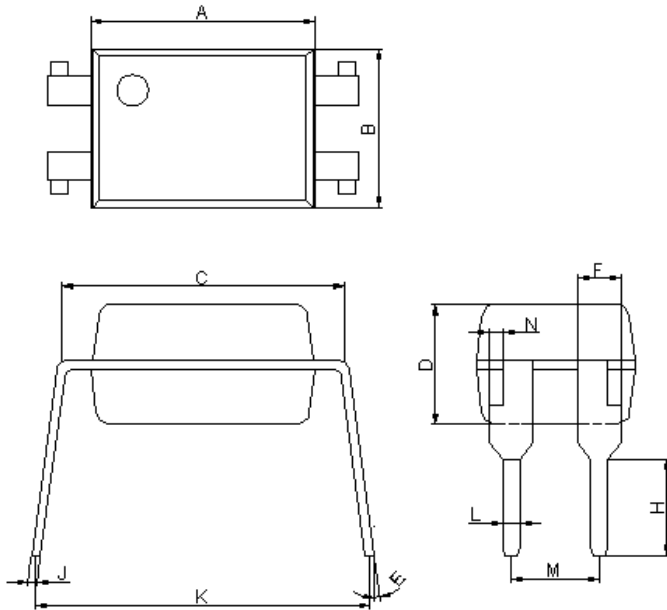

Figure 9. Switching Time Test Circuit & Waveforms

Package Outline Dimensions (Unit: mm)

DIP-4L



Dimension	Min.	Max.
A	6.40	6.60
B	4.50	4.70
C	7.90	8.30
D	3.28	3.68
E	2°	8°
F	1.15	1.35
H	2.70	2.90
J	0.20	0.30
K	8.86	9.31
L	0.40	0.60
M	2.44	2.64
N	0.30	0.50

DIP-4L-M

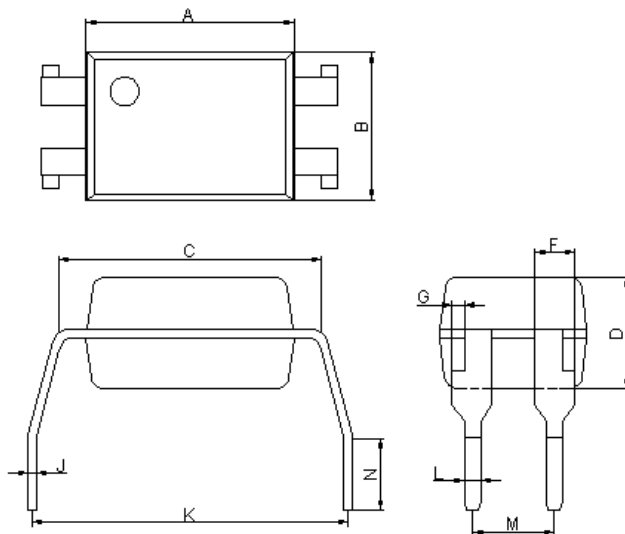

Dimension	Min.	Max.
A	6.40	6.60
B	4.50	4.70
C	7.90	8.30
D	3.28	3.68
F	1.15	1.35
G	0.30	0.50
J	0.20	0.30
K	9.86	10.46
L	0.40	0.60
M	2.44	2.64
N	2.40	2.90

SOP-4L

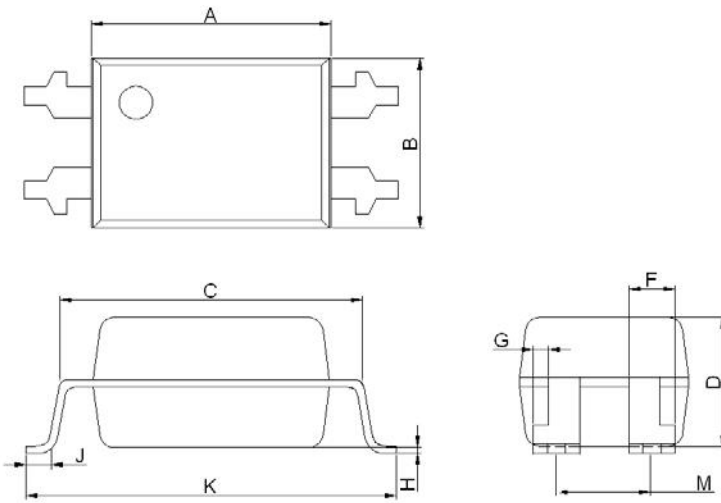

Dimension	Min.	Max.
A	6.40	6.60
B	4.50	4.70
C	7.90	8.30
D	3.28	3.68
F	1.15	1.35
G	0.30	0.50
H	0.00	0.20
J	0.9	1.2
K	9.80	10.30
M	2.49	2.69

Mounting Pad Layout (Unit: mm)

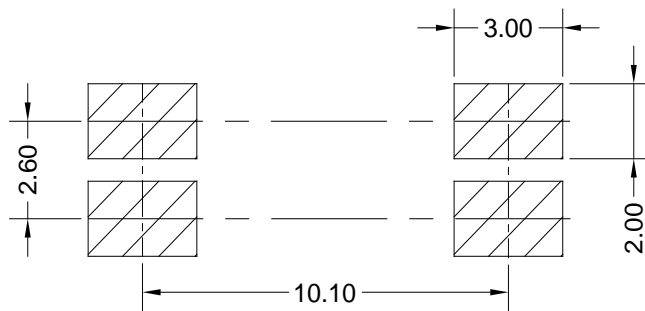

UNIT:mm

Important Notice

Changzhou Galaxy Century Microelectronics (GME) reserves the right to make changes without further notice to any product information (copyrighted) herein to make corrections, modifications, improvements, or other changes. GME does not assume any liability arising out of the application or use of any product described herein; neither does it convey any license under its patent rights, nor the rights of others.