

Features

- Epitaxial planar die construction
- Built-in biasing resistors (R_1 : 10k Ω , R_2 : 47k Ω)
- Also available in lead free version

HF

Mechanical Data

- Case: SOT-23, SOT-323, SOT-523, SOT-723, DFN1006-3
- Molding Compound: UL Flammability Classification Rating 94V-0
- Terminals: Matte tin-plated leads; solderability-per MIL-STD-202, Method 208

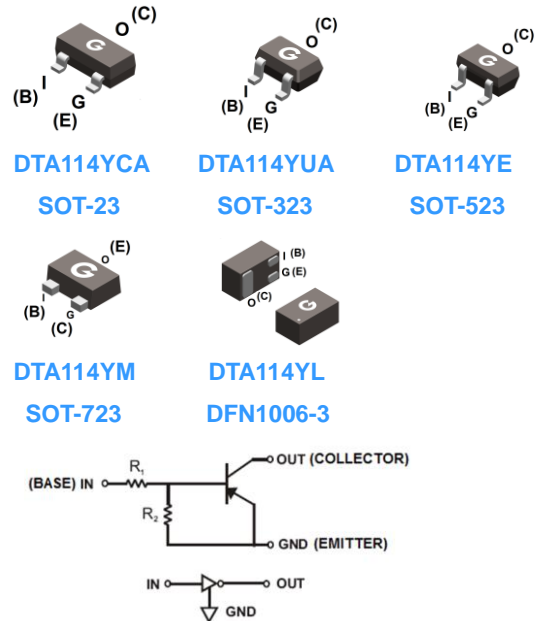

Ordering Information

Part Number	Package	Shipping Quantity	Marking Code
DTA114YCA	SOT-23	3000 pcs / Tape & Reel	54
DTA114YUA	SOT-323	3000 pcs / Tape & Reel	54
DTA114YE	SOT-523	3000 pcs / Tape & Reel	54
DTA114YM	SOT-723	10000 pcs / Tape & Reel	54
DTA114YL	DFN1006-3	10000 pcs / Tape & Reel	54

Maximum Ratings (@ $T_A = 25^\circ\text{C}$ unless otherwise specified)

Parameter	Symbol	Value					Unit
		SOT-23	SOT-323	SOT-523	SOT-723	DFN1006-3	
Supply Voltage	V_{CC}	-50					V
Input Voltage	V_I	+6 to -40					V
Output Current	I_O	-70					mA
Collector Current	$I_{C(Max)}$	-100					mA
Power Dissipation	P_D	200	200	150	100	100	mW
Junction Temperature Range	T_J	-55 ~ +150					$^\circ\text{C}$
Storage Temperature Range	T_{STG}	-55 ~ +150					$^\circ\text{C}$

Electrical Characteristics (@ $T_A = 25^\circ\text{C}$ unless otherwise specified)

Parameter	Symbol	Test Condition	Min.	Typ.	Max.	Unit
Input Voltage	$V_{I(OFF)}$	$V_{CC} = -5\text{V}, I_o = -100\mu\text{A}$	-0.3	-	-	V
Input Voltage	$V_{I(ON)}$	$V_o = -0.3\text{V}, I_o = -1\text{mA}$	-	-	-1.4	V
Output Voltage	$V_{O(on)}$	$I_o = -5\text{mA}, I_i = -0.25\text{mA}$	-	-	-0.3	V
Input Current	I_i	$V_i = -5\text{V}$	-	-	-0.88	mA
Output Current	$I_{O(off)}$	$V_{CC} = -50\text{V}, V_i = 0\text{V}$	-	-	-0.5	μA
DC Current Gain	G_I	$V_o = -5\text{V}, I_o = -5\text{mA}$	68	-	-	-
Input Resistor	R_1		7	10	13	k Ω
Resistance ratio	R_2/R_1		3.7	4.7	5.7	-
Gain-Bandwidth Product	f_T	$V_{CE} = -10\text{V}, I_E = -5\text{mA}$ $f = 100\text{MHz}$	-	250	-	MHz

Ratings and Characteristic Curves (@ $T_A = 25^\circ\text{C}$ unless otherwise specified)

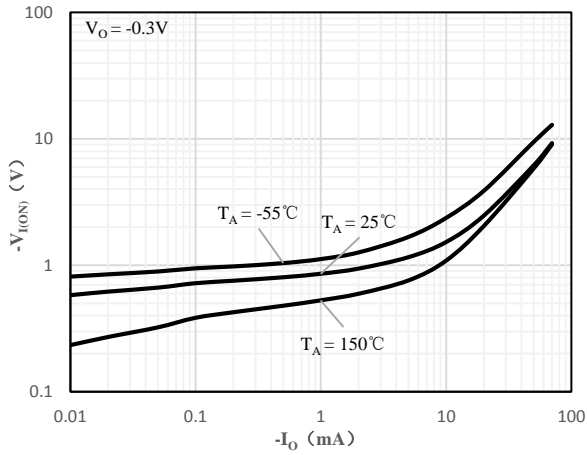

Fig 1 Input Voltage vs Output Current

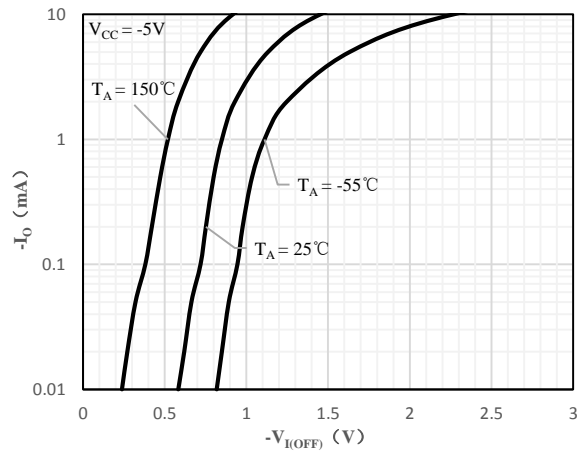

Fig 2 Output Current vs Input Voltage

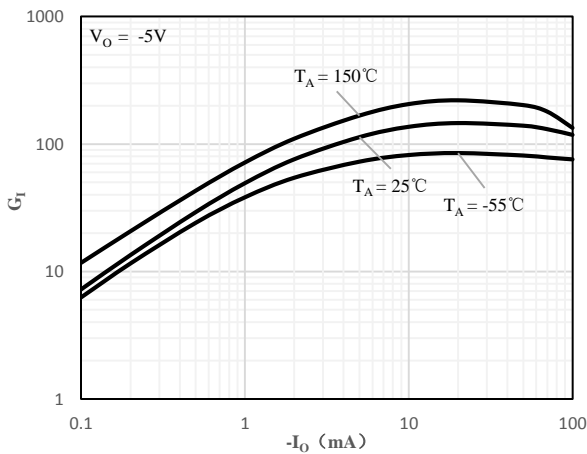

Fig 3 DC Current Gain vs Output Current

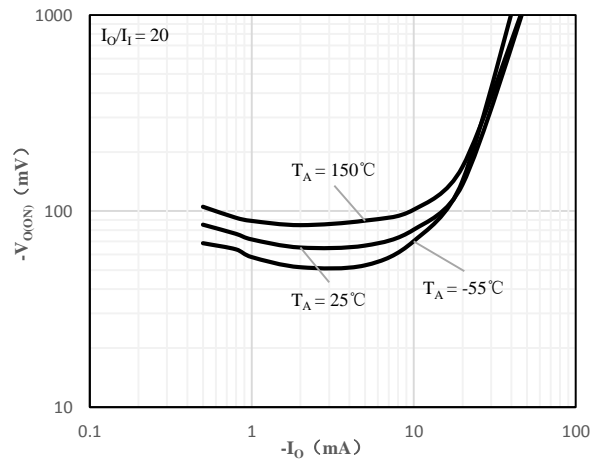
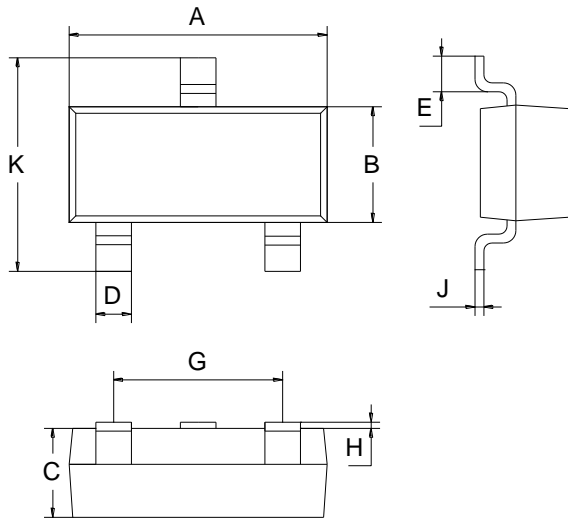
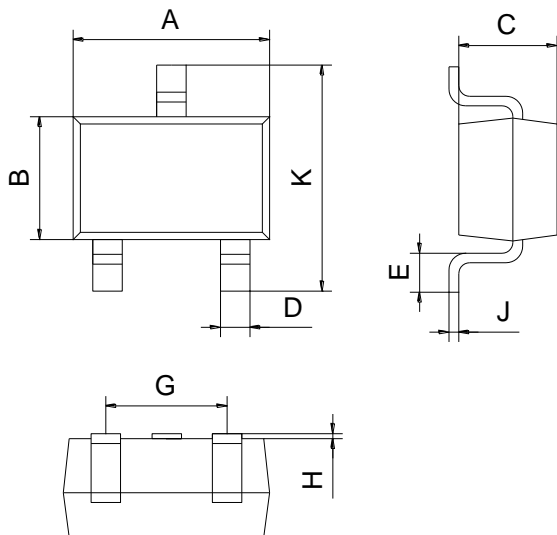

Fig 4 Output Voltage vs Output Current

Package Outline Dimensions (Unit: mm)



SOT-23		
Dimension	Min.	Max.
A	2.70	3.10
B	1.10	1.50
C	0.90	1.10
D	0.30	0.50
E	0.35	0.48
G	1.80	2.00
H	0.02	0.10
J	0.05	0.15
K	2.20	2.60



SOT-323		
Dimension	Min.	Max.
A	2.00	2.20
B	1.15	1.35
C	0.90	1.10
D	0.15	0.35
E	0.25	0.40
G	1.20	1.40
H	0.02	0.10
J	0.05	0.15
K	2.20	2.40

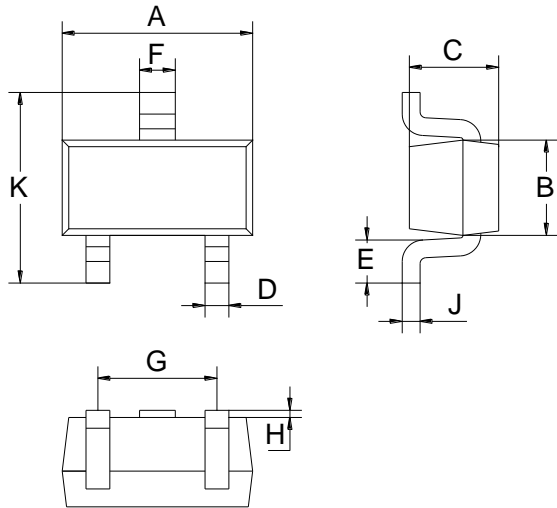

SOT-523		
Dimension	Min.	Max.
A	1.50	1.70
B	0.75	0.85
C	0.60	0.80
D	0.15	0.30
E	0.30	0.40
F	0.25	0.40
G	0.90	1.10
H	0.02	0.10
J	0.08	0.18
K	1.45	1.75

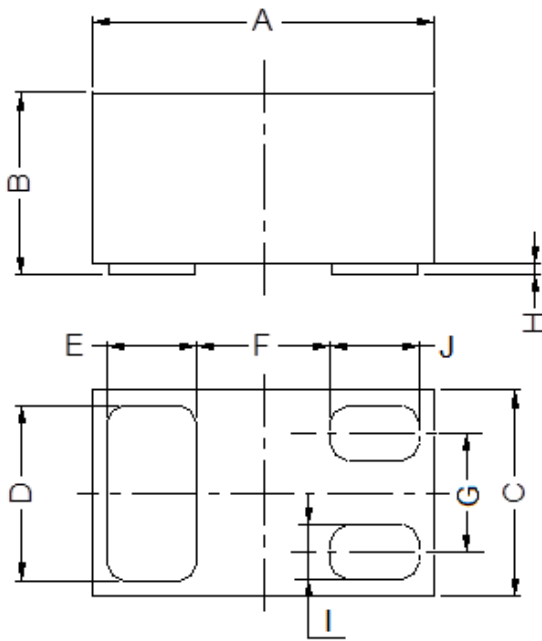

DFN1006-3			
Dimension	Min.	Typ.	Max.
A	0.95	1.00	1.075
B	0.47	0.50	0.53
C	0.55	0.60	0.675
D	0.45	0.50	0.55
E/J	0.20	0.25	0.30
F	-	0.40	-
G	-	0.35	-
H	0	0.03	0.05
I	0.10	0.15	0.20

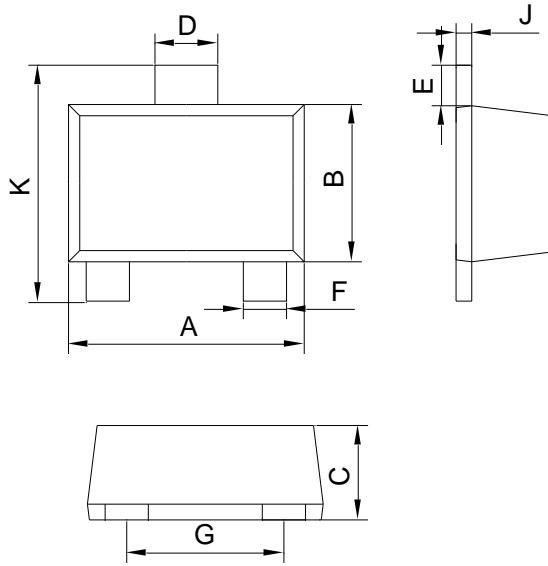

SOT-723		
Dimension	Min.	Max.
A	1.10	1.30
B	0.70	0.90
C	0.40	0.54
D	0.22	0.42
E	0.10	0.30
F	0.12	0.32
G	0.70	0.90
J	0.08	0.15
K	1.10	1.30

Mounting Pad Layout (Unit: mm)

SOT-23

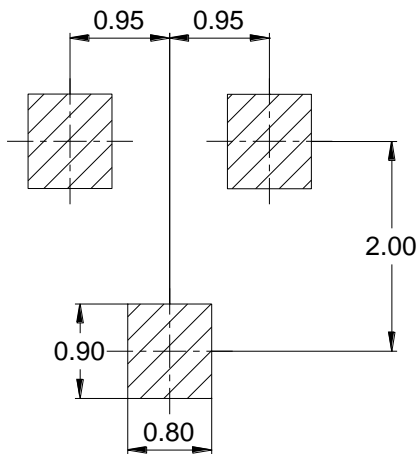

SOT-323

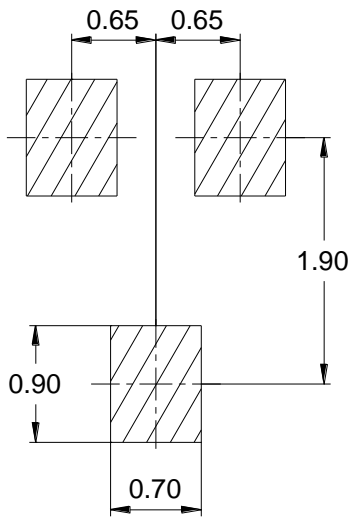

SOT-523

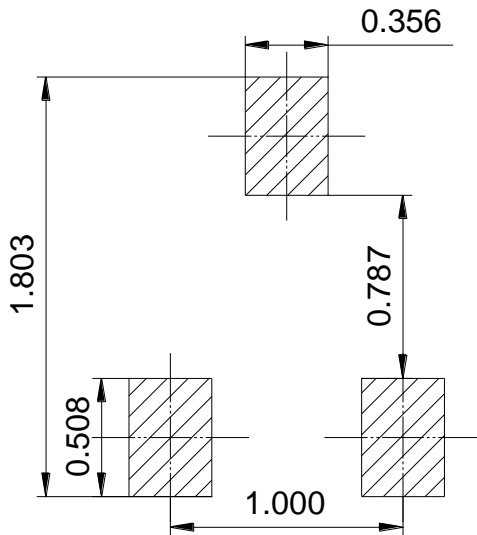

DFN1006-3

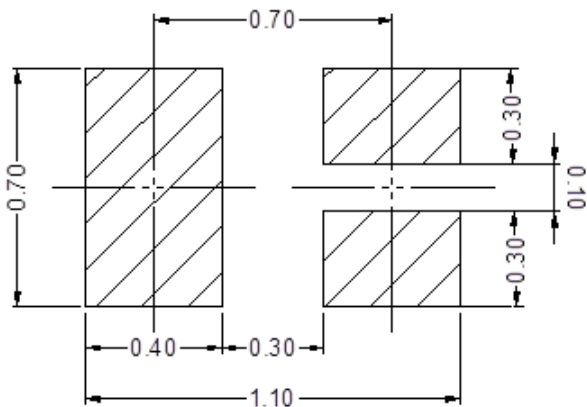

SOT-723

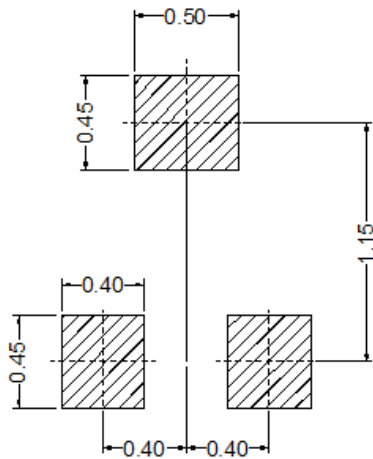

IMPORTANT NOTICE

Changzhou Galaxy Century Microelectronics (GME) reserves the right to make changes without further notice to any product information (copyrighted) herein to make corrections, modifications, improvements, or other changes. GME does not assume any liability arising out of the application or use of any product described herein; neither does it convey any license under its patent rights, nor the rights of others.